

Operating Instructions (EN)

MODELS:

26" DISK
28" DISK
30" DISK
34" DISK

24" CYLINDRICAL
27" CYLINDRICAL
30" CYLINDRICAL
34" CYLINDRICAL

28" EDGE
32" EDGE

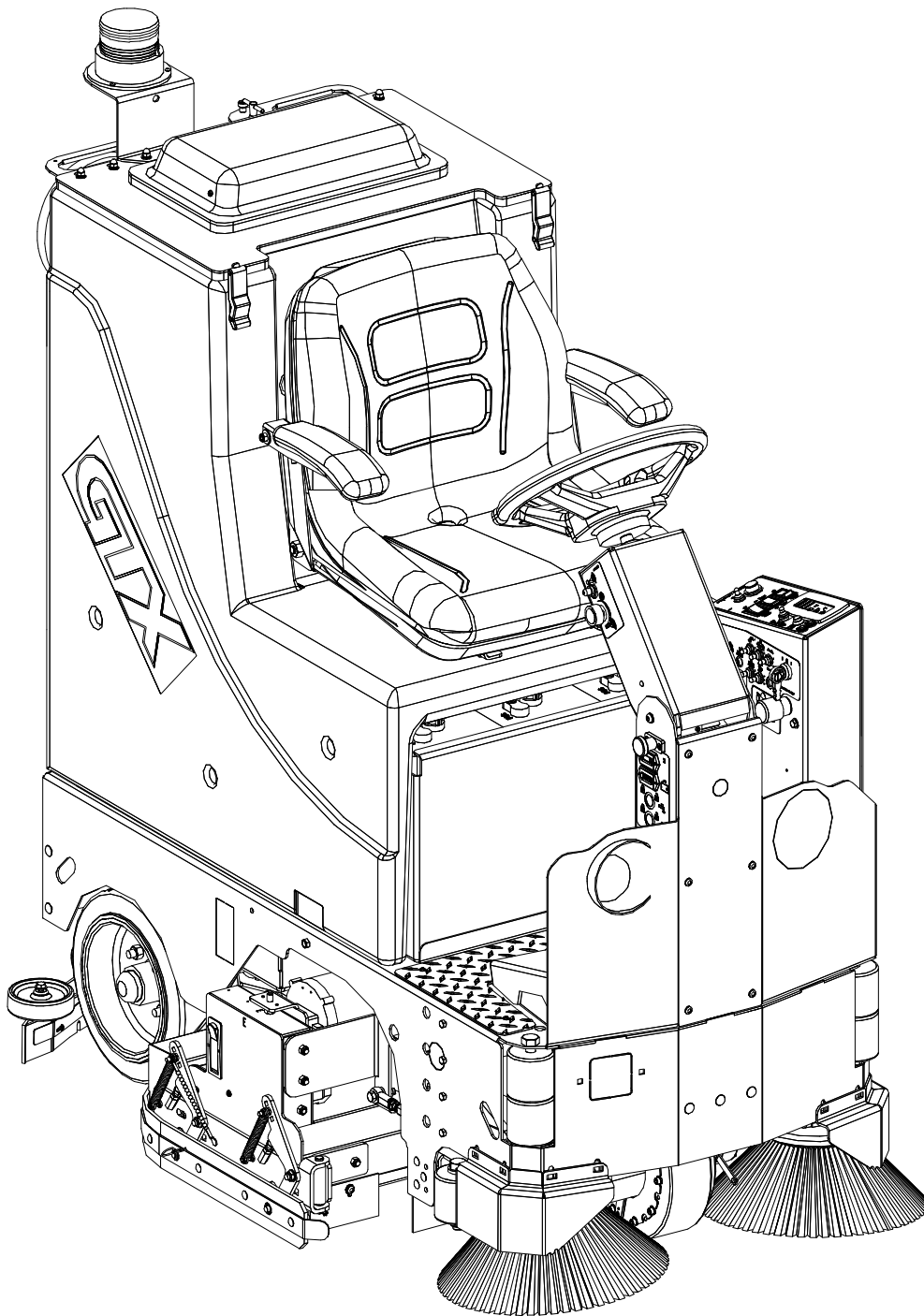

Read these Instructions before using the machine.



Read these Safety Messages before using the machine.

INTRODUCTION

This manual is furnished with each new machine. This manual will allow the Operator to get the best performance out of your RPS manufactured Scrubber-Drier, Sweeper, Burnisher, or Orbital Scrubber. Read this manual thoroughly before operating or servicing the machine.

This machine will provide excellent performance, but the best results will be obtained at the most minimum costs if:

- The machine is regularly maintained - per the machine Preventative Maintenance instructions provided.
- The machine is operated with reasonable care and caution.
- The machine is maintained with manufacturer supplied parts.

ABOUT THIS MANUAL

TABLE OF CONTENTS: Tells you where to look in the manual.

SAFETY MESSAGES: Section contains important information regarding hazard or unsafe practices of the machine. Levels of hazards are identified that could result in product or personal injury, or severe injury resulting in death.

OPERATION CONTROLS / MACHINE COMPONENTS: Shows you the different machine controls and features.

MACHINE SETUP: Tells you how to setup machine from un-crating to installing squeegee and brushes.

MACHINE OPERATION: Section is to familiarize the operator with the operation and function of the machine.

BATTERY CHARGING: Shows you how to charge the batteries (on-board and off board charging).

MAINTENANCE: This section contains preventative maintenance to keep the machine and it's components in good working condition. They are listed in this general order:

- Batteries
- Scrub Brushes
- Adjusting Squeegee
- Service Schedule
- Machine Trouble Shooting

TROUBLE SHOOTING: A list of common problems that may occur.

MACHINE SPECS: Tells you Machine Specifications for the various parts of the machine.

MACHINE INSTALL FORM: Should be filled out upon machine installation and faxed to 1-866-632-6961 or online at www.rpscoperation.com.

WARRANTY POLICY: Tells you coverage, exclusions and limitations to warranty.

NOTE: The serial number of your machine is located on the lower half of the control panel of the machine.

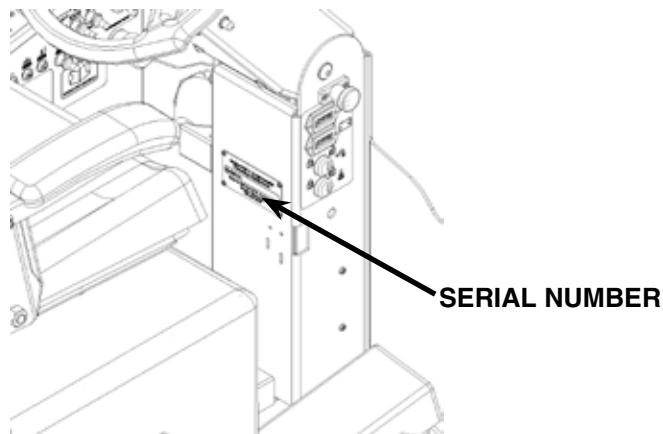



AS OUR POLICY IS ONE OF CONSTANT IMPROVEMENT - ALL INFORMATION AND SPECIFICATIONS ARE SUBJECT TO CHANGE WITHOUT NOTICE.

TABLE OF CONTENTS

<p>Introduction.....2</p> <p>About This Manual.....2</p> <p>Table of Contents.....3</p> <p>Safety Messages.....4</p> <p>Safety Label Locations.....6</p> <p>Operation Controls.....7</p> <p>Operation Controls.....8</p> <p>Machine Components.....9</p> <p>Machine Components.....10</p> <p>LCD Screen Menu Displays:.....11</p> <p>Machine Setup.....12</p> <p style="padding-left: 20px;">Un-Crating Machine:.....12</p> <p style="padding-left: 20px;">Connecting Batteries:.....12</p> <p style="padding-left: 20px;">Adjusting Squeegee:.....13</p> <p style="padding-left: 20px;">Removing Squeegee:.....13</p> <p style="padding-left: 20px;">Replacing or Rotating Squeegee Blades:.....13</p> <p style="padding-left: 20px;">Installing Disk Pad Driver or Brush:.....14</p> <p style="padding-left: 20px;">Installing Driver Pads:.....14</p> <p style="padding-left: 20px;">Installing Cylindrical Brush:.....15</p> <p style="padding-left: 20px;">Installing EDGE Pads:.....16</p> <p style="padding-left: 20px;">Leveling EDGE Decks:.....16</p> <p style="padding-left: 20px;">Leveling Disk Decks:.....17</p> <p style="padding-left: 20px;">Leveling Cylindrical Decks:.....17</p> <p>Machine Operation.....18</p> <p style="padding-left: 20px;">Pre-Cleaning Checklist:.....18</p> <p style="padding-left: 20px;">Operating Hints:.....18</p> <p style="padding-left: 20px;">One Pass Scrubbing:.....19</p> <p style="padding-left: 20px;">Vacuum Only:.....19</p> <p style="padding-left: 20px;">Adjust Solution Flow:.....19</p> <p style="padding-left: 20px;">Adjust Shrouds Blades:.....20</p> <p style="padding-left: 20px;">Adjust Wipers Blades:.....20</p> <p style="padding-left: 20px;">Adjust Shrouds:.....20</p> <p style="padding-left: 20px;">Adjust Cylindrical Wipers:.....20</p> <p style="padding-left: 20px;">Open Recovery Lid:.....21</p> <p style="padding-left: 20px;">Flush Recovery Tank:.....21</p> <p style="padding-left: 20px;">Clean “Drain Saver”:.....21</p> <p style="padding-left: 20px;">Clean Vacuum Screen:.....21</p> <p style="padding-left: 20px;">Solution Filter:.....22</p> <p style="padding-left: 20px;">Cleaning Solution Filter:.....22</p>	<p style="padding-left: 20px;">Squeegee Up:.....22</p> <p style="padding-left: 20px;">Squeegee Down:.....22</p> <p style="padding-left: 20px;">Draining Solution Tank:.....23</p> <p style="padding-left: 20px;">Draining Recovery Tank:.....23</p> <p style="padding-left: 20px;">Releasing Parking Brake Override Lever:.....23</p> <p>Battery Charging.....24</p> <p style="padding-left: 20px;">External Battery Charging:.....24</p> <p>On-Board Charger.....25</p> <p style="padding-left: 20px;">On-Board Battery Charging (Optional):.....25</p> <p style="padding-left: 20px;">Description of LED.....25</p> <p>Battery Maintenance Guide.....26</p> <p style="padding-left: 20px;">Safety:.....26</p> <p style="padding-left: 20px;">Inspection and Cleaning:.....26</p> <p style="padding-left: 20px;">Storage:.....26</p> <p style="padding-left: 20px;">Watering:.....26</p> <p>Maintenance.....27</p> <p style="padding-left: 20px;">Daily Maintenance:.....27</p> <p style="padding-left: 20px;">Weekly Maintenance:.....27</p> <p style="padding-left: 20px;">Monthly maintenance:.....27</p> <p style="padding-left: 20px;">Yearly Maintenance:.....27</p> <p style="padding-left: 20px;">Storing Machine:.....27</p> <p style="padding-left: 20px;">Checking Battery Specific Gravity:.....27</p> <p>PM Records.....28</p> <p>Trouble-shooting.....30</p> <p>Trouble-Shooting Central Command.....32</p> <p>Machine Specs.....34</p> <p>Common Wear Parts.....35</p> <p style="padding-left: 20px;">Round Disk Brushes:.....35</p> <p style="padding-left: 20px;">Round Disk Pads:.....35</p> <p style="padding-left: 20px;">EDGE Pads and Screens:.....35</p> <p style="padding-left: 20px;">New Style Cylindrical Brushes:.....36</p> <p style="padding-left: 20px;">Old Style Cylindrical Brushes:.....36</p> <p>Soap Choices.....37</p> <p>Standard Warranty Policy.....39</p> <p>Machine Install / Warranty Registration.....40</p>
-----------------------------------------------------------------------------------------------------------------------------------------------------------------------------------------------------------------------------------------------------------------------------------------------------------------------------------------------------------------------------------------------------------------------------------------------------------------------------------------------------------------------------------------------------------------------------------------------------------------------------------------------------------------------------------------------------------------------------------------------------------------------------------------------------------------------------------------------------------------------------------------------------------------------------------------------------------------------------------------------------------------------------------------------------------------------------------------------------------------------------------------------------------------------------------------------------------------------------------------------------------------------------------------------------------------------------------------------------------------------------------------------------------------------------------------------------------------------------------------------------------------------------------------------------------------------------------------------------------------------------------------------------------------------------------------------------------------------------------------------------------------------------------------------------------------------------------------------------------------------------------------------------------------------------------------------------------------------------------------------------------------------------------------------------------------------------------------------------------------------------------------------------------------------------------------------------------------------------------------------------------------------------------------------------	------------------------------------------------------------------------------------------------------------------------------------------------------------------------------------------------------------------------------------------------------------------------------------------------------------------------------------------------------------------------------------------------------------------------------------------------------------------------------------------------------------------------------------------------------------------------------------------------------------------------------------------------------------------------------------------------------------------------------------------------------------------------------------------------------------------------------------------------------------------------------------------------------------------------------------------------------------------------------------------------------------------------------------------------------------------------------------------------------------------------------------------------------------------------------------------------------------------------------------------------------------------------------------------------------------------------------------------------------------------------------------------------------------------------------------------------------------------------------------------------------------------------------------------------------------------------------------------------------------------------------------------------------------------------------------------------------------------------------------------------------------------------------------------------------------------------------------------------------------------------------------------------------------------------------------------------------------------------------------------------------------------------------------------------

SAFETY MESSAGES

You will see four kinds of safety reminders in this manual:

 DANGER
DANGER indicates a hazardous situation which, if not avoided, will result in death or serious injury.
 WARNING
WARNING indicates a potentially hazardous situation which, if not avoided, could result in death or serious injury.
 CAUTION
CAUTION indicates a potentially hazardous situation which, if not avoided, could result in minor or moderate injury or damage to this machine or nearby objects. CAUTION also can be used to alert against unsafe practices.
NOTICE
NOTICE indicates information considered important, but not hazard-related. This safety message may be related to property damage or warranty warnings.

Your safety, and that of others, is very important. Operating this machine safely is an important responsibility.

DO NOT OPERATE THIS MACHINE UNLESS:

- You are trained and authorized to do so
- You have read and understood this Operator's Manual
- On surfaces with greater than a 2% grade unless this machine is equipped with a functional parking brake.

WHEN OPERATING THIS MACHINE:

- Remove loose objects from the floor that could be projected from the rotating Brushes
- Keep your hands and feet away from the rotating Brushes
- Do not operate this machine where flammable liquids are present
- Use caution when maneuvering

BEFORE LEAVING THE MACHINE:

- Park the machine on a level surface
- Turn the machine off

BEFORE SERVICING THE MACHINE:

- Disconnect the Batteries

DANGER

Explosive hydrogen gas forms when Batteries are charging. An open flame or spark can cause this gas to explode. Serious personal injury or property damage could occur. Only charge the Batteries in this machine in a well ventilated area.

DANGER

Flammable materials can cause an explosion or fire. Do not use flammable materials in Tank or pick up.

⚠ WARNING

The Batteries in this machine produce hazardous voltage which can cause electrical shock, burns and/or electrocution. Always disconnect Batteries before servicing this machine.

⚠ WARNING

When climbing or descending ramps, always drive machine forward. To avoid overturning the machine, Do not back down ramps. Do not drive across inclines. Do not turn while ascending or descending ramps. Overturning the machine can cause serious injury or death.

⚠ WARNING

Do not use water that exceeds 135°F / 57°C. If water is above said temperature, this will void the Tank Warranty.

⚠ WARNING

Do not park this machine on ramps or slopes. Always park this machine on a level, hard surface. Do not operate this machine outdoors or on uneven surfaces.

⚠ WARNING

The Batteries in this machine contain sulfuric acid, which causes burns to skin. If battery acid contacts clothing or skin, rinse the effected area with cold water immediately. If battery acid gets on your face or in your eyes, flush the area immediately with cold water and seek medical attention.

⚠ WARNING

To avoid electrical shock, do not operate this machine over electrical floor outlets.

⚠ CAUTION

To avoid damage to this machine, use only cleaning solutions and replacement parts recommended by the manufacturer.

⚠ CAUTION

Do not operate this machine if any parts have been damaged or removed.

⚠ WARNING

Dress safely. Do not wear rings or metal wrist watches when servicing this machine, as they can cause an electrical short circuit which can cause serious burns.

⚠ WARNING

Do not remove, paint over or destroy warning decals. If warning decals become damaged, call 1-262-681-3583 for free replacements.

⚠ WARNING

Dress safely. Do not wear a neck tie, scarf, or any loose or dangling clothing while operating this machine. Loose or dangling clothing or neck-wear can tangle in rotating parts, causing serious injury or death.

⚠ WARNING

Always turn off this machine before leaving it unattended. Do not allow untrained persons to operate this machine.

⚠ WARNING

NO RIDERS. Do not carry passengers on this machine. Do not use this machine as a stepladder or work platform.

⚠ WARNING

Understand the dynamic braking system before you operate the machine on ramps. Machine may coast.

⚠ WARNING

Before you service a Battery, always wear face protection, protective gloves and protective clothing. Battery acid or battery explosion can cause serious injuries.

⚠ CAUTION

Always use the automatic battery charger provided by the manufacturer of this machine to charge the Batteries of this machine. It is designed to charge the Batteries at the appropriate rate. If you must use a different charger, disconnect the Batteries before charging to avoid damage to the electronic speed controller.

⚠ CAUTION

To avoid damage to the electronic control components of this machine, Do not store this machine outdoors. Do not pressure wash this machine.

SAFETY LABEL LOCATIONS

Read and obey all Safety Labels on your GTX Floor Scrubber. If you have questions about these labels, ask your supervisor.

These images indicate where on the GTX Safety Labels are located. If ever the labels become illegible, worn off, or torn, promptly report it to your supervisor and replace it.

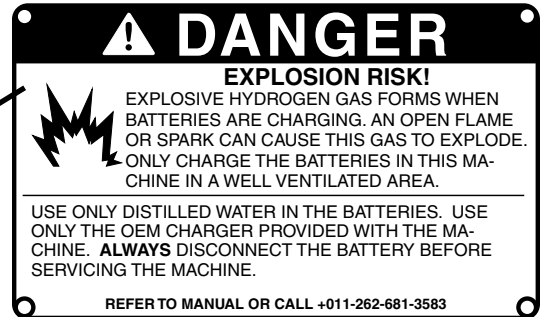
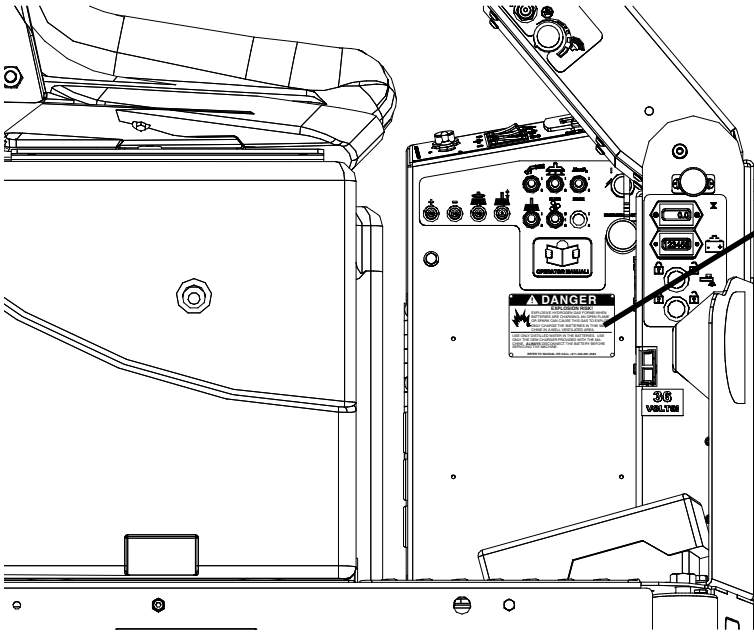

BATTERY CHARGING LABEL
PART #: 253-7280

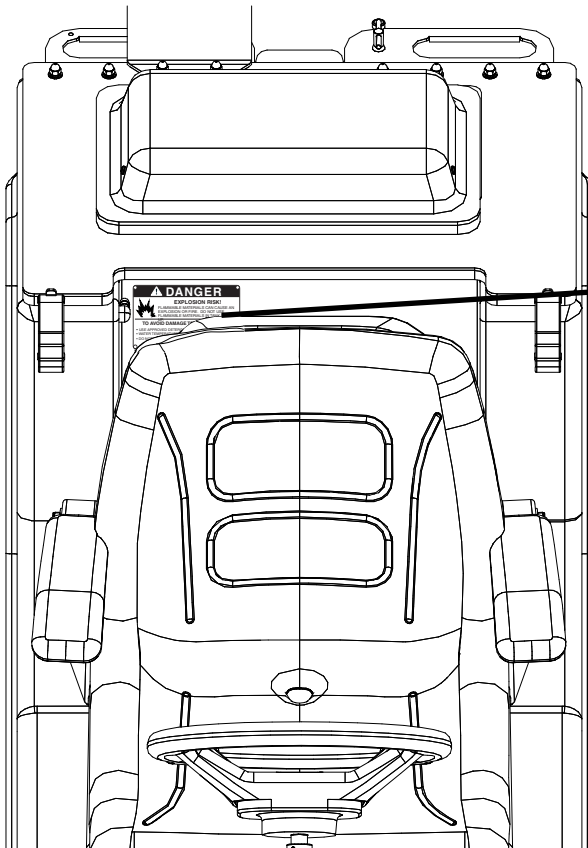

TANK LABEL
PART #: 5-728

OPERATION CONTROLS

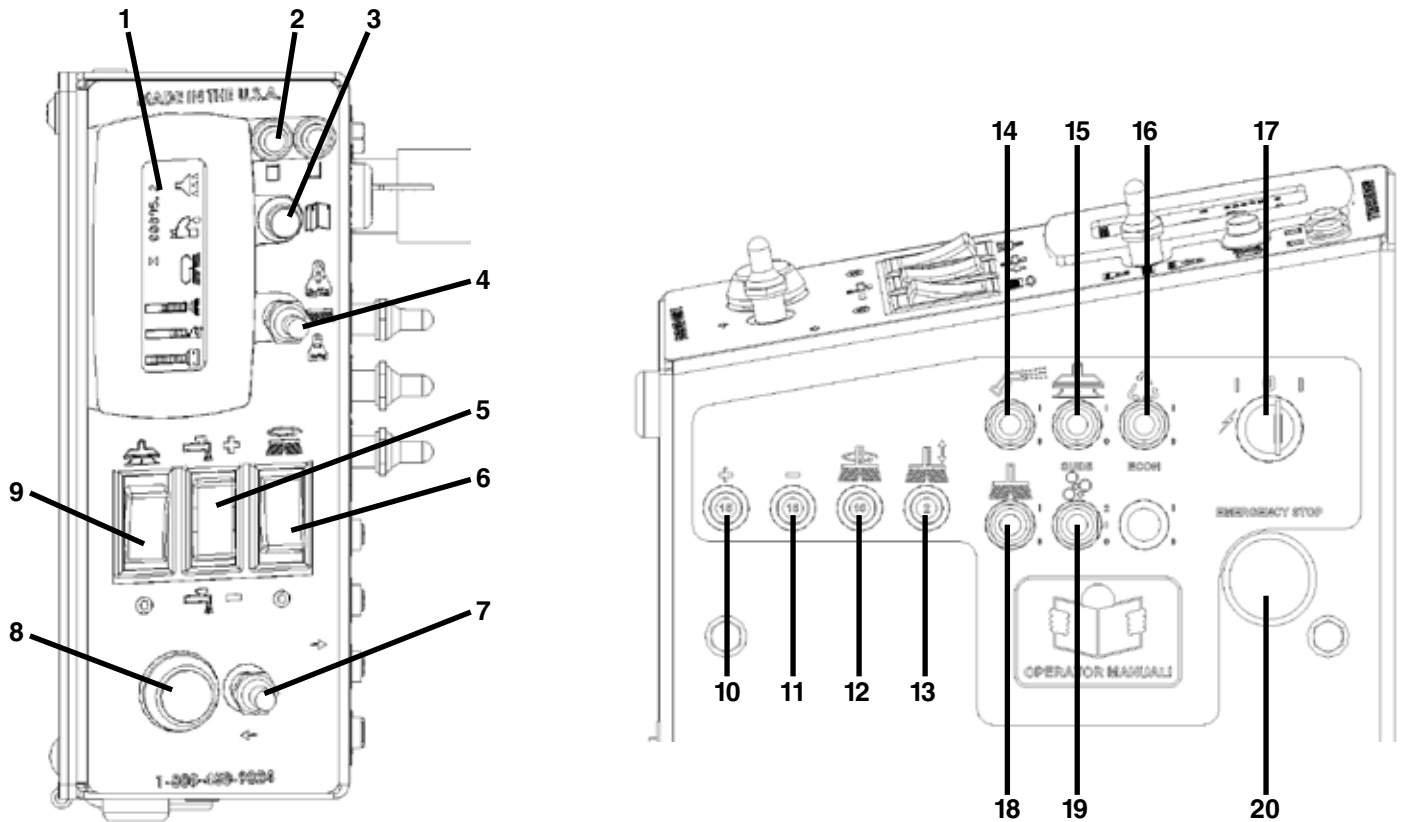

1. **LCD SCREEN:** Lists functions and settings of the machine
2. **HIGH WATER RECOVERY LIGHT [RED]:** Indicates when the Recovery Tank is nearly full
3. **MENU CONTROL:** Scrolls through different options on the LCD display - there are 3 different screens it will scroll through
4. **DOWN PRESSURE TOGGLE SWITCH [BLACK]:** Controls the pressure to the Scrubdeck - push up (+) for higher down pressure, down (-) for lower pressure
5. **SOLUTION FLOW CONTROL SWITCH:** Push down (-) to reduce and push up (+) to increase the solution flow
6. **SCRUBDECK SWITCH:** Raises and lowers the Scrubdeck
7. **REVERSE SWITCH:** Pull back for machine drive reverse
8. **UNITOUCH BUTTON:** Activates Scrubdeck, Squeegee, and Solution Flow simultaneously
9. **SQUEEGEE SWITCH:** Raises and lowers the Squeegee
10. **CIRCUIT BREAKER:** 15 amp Positive Bus Bar
11. **CIRCUIT BREAKER:** 15 amp Negative Bus Bar
12. **CIRCUIT BREAKER:** 10 amp Side Broom Motors
13. **CIRCUIT BREAKER:** 2 amp Side Broom Lift Actuator
14. **SPRAY JET [BLUE] (OPTIONAL):** Activates Water Pump for remote Spray Wand
15. **VACUUM SWITCH [WHITE] (OPTIONAL):** Activates Vacuum Motor for remote Vacuum Wand
16. **ECON TOGGLE SWITCH [GREEN] (OPTIONAL):** Reduces power to give machine a longer run time
17. **KEY SWITCH:** Turns power of the machine *ON* and *OFF*
18. **SIDE BROOM SWITCH [YELLOW] (OPTIONAL):** Turns power of the side brooms *ON* and *OFF* as well as lifts and lowers automatically
19. **“ON-BOARD” SOAP SYSTEM [GRAY] (OPTIONAL):** Dispenses soap directly to the Scrubdeck level
20. **EMERGENCY STOP (OPTIONAL):** 1 button push machine shut down in case of emergency

OPERATION CONTROLS

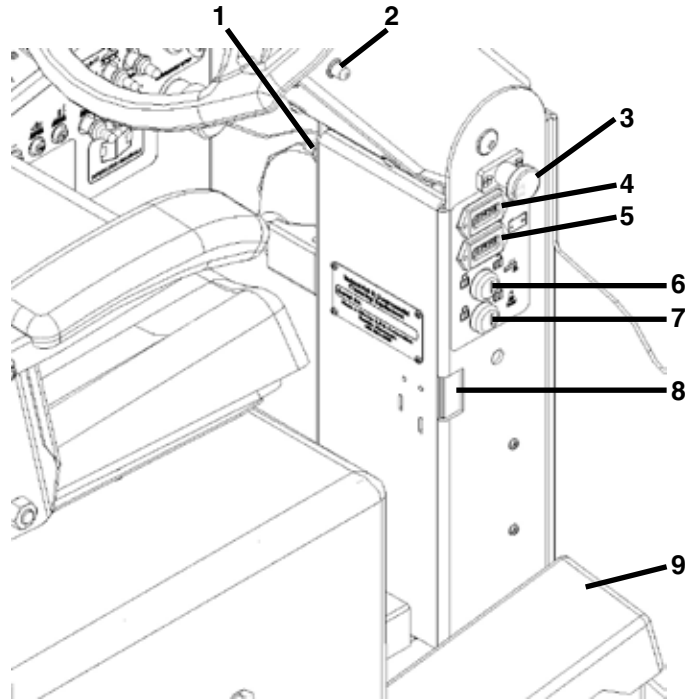

1. **HEADLIGHT SWITCH:** Turns power of the Headlight *ON* and *OFF*
2. **HORN:** Sounds the horn for warning oncoming traffic
3. **ADJUSTABLE STEERING:** Four settings for operator comfort and ease of entry
4. **HOUR METER:** Hour meter to indicate complete time machine has been *ON*
5. **RECHARGE CYCLE METER:** Shows the amount of charges on a machine
6. **MANAGER SOLUTION LOCKOUT (OPTIONAL):** Allows ability to set Solution Flow and then remove Key to not allow changing of parameters
7. **MANAGER DOWN PRESSURE LOCKOUT (OPTIONAL):** Allows ability to set Down Pressure and then remove Key to not allow changing of parameters
8. **CHARGER PORT:** Grey 50 used to receive charger input for optional external charger
9. **FOOT PEDAL:** Controls the acceleration and deceleration of the machine

MACHINE COMPONENTS

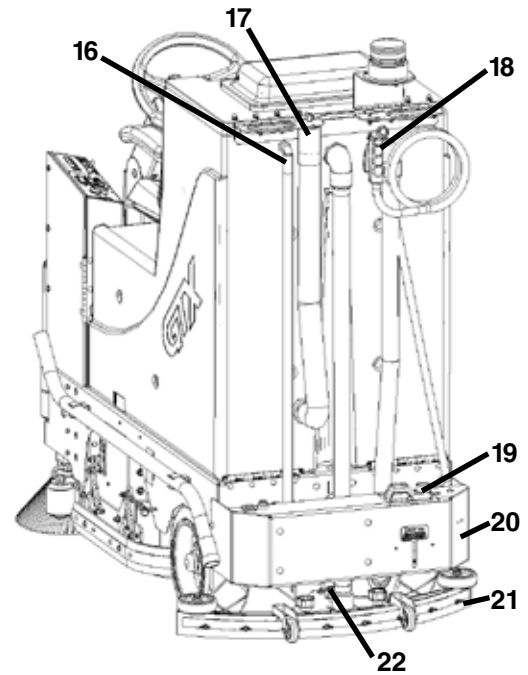
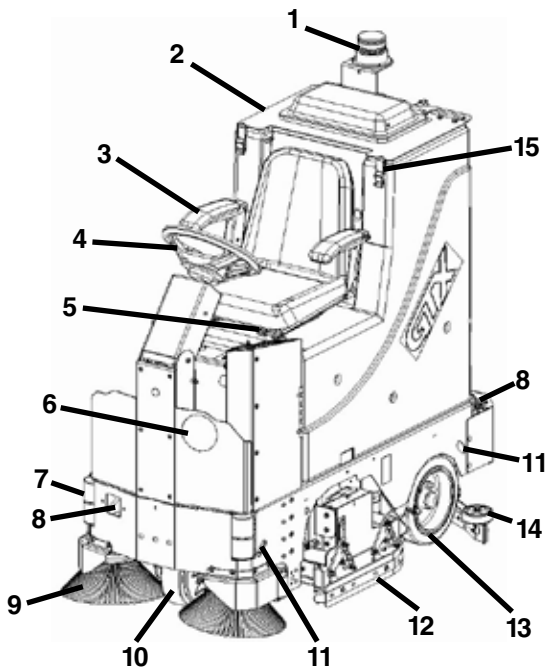

1. **STROBE LIGHT (OPTIONAL):** Optional Strobe Light silently alerts others nearby of the machines presence
2. **RECOVERY TANK LID:** Latch must be secured for Recovery Tank to seal properly
3. **ADJUSTABLE SEAT WITH ARM RESTS:** The machine is equipped with an ergonomic seat with adjustable arm rests and positioning
4. **STEERING WHEEL:** Steers the main Drive Wheel
5. **SEAT ADJUSTMENT:** Permits the Seat to be adjusted forward and backward for operator comfort
6. **HEADLIGHT:** Helps you see in low light areas and to warn oncoming traffic
7. **POLYURETHANE ROLLERS:** Helps prevent damage to machine and objects you may drive near
8. **ONBOARD CHARGER (OPTIONAL):** Two optional placements for the Onboard Charger Option which allows the operator to charge machine by plugging machine directly into any standard wall outlet
9. **SIDE BROOMS (OPTIONAL):** Optional Side Brooms allow for debris clean up directly up to walls
10. **FRONT DRIVE TIRE:** Drives and steers the machine
11. **TIE DOWN POINTS:** Location for tie down straps during transport
12. **SIDE WIPERS:** Controls water on turns by directing it to the Squeegee
13. **REAR WHEELS:** Cut for complete water control
14. **SQUEEGEE ROLLERS:** Helps protect the Squeegee
15. **TANK LATCHES:** Permits access to the Recovery Tank
16. **SOLUTION SIGHT GAUGE & DRAIN HOSE:** Shows precise level of cleaning solution in Tank while also used as a Solution Tank drain hose
17. **RECOVERY DRAIN HOSE:** Allows for controlled draining of the Recovery Tank
18. **SPRAY JET HOSE (OPTIONAL):** Optional Spray Jet hose allows operator to utilize the Solution Tanks cleaning solution in areas where the machine may not reach to scrub
19. **ONBOARD SUDS SYSTEM (OPTIONAL):** SUDs system allows the operator to precisely add soap directly to the Scrubdeck
20. **REAR BUMPER:** Offers squeegee system protection from damage
21. **SQUEEGEE BLADE:** Squeegees water to be recovered by the vacuum hose
22. **SQUEEGEE PITCH ADJUSTMENT:** Recovers dirty water from the floor to be recovered by Vacuum Hose

MACHINE COMPONENTS

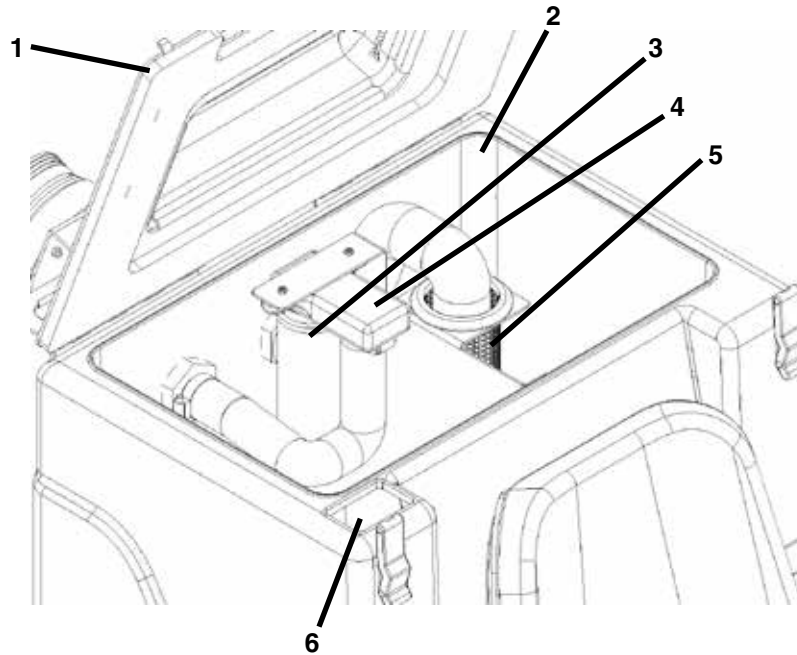

1. **RECOVERY ACCESS DOOR:** Used for flushing out Recovery Tank with fresh water
2. **RECOVERY TANK:** Holds approximately 35 gallons of dirty “recovered” water
3. **FOAM PROTECTION SCREEN:** Used to protect the Vacuum Motor from debris
4. **VACUUM SCREEN BOX:** Houses the Dual Stainless Vacuum Screen & Shut-off balls
5. **DRAIN SAVER:** Prevents debris from clogging drain
6. **SOLUTION TANK FILL POINT:** Holds approximately 35 gallons of clean water

LCD SCREEN MENU DISPLAYS:

SCREEN #1 (OPERATOR)

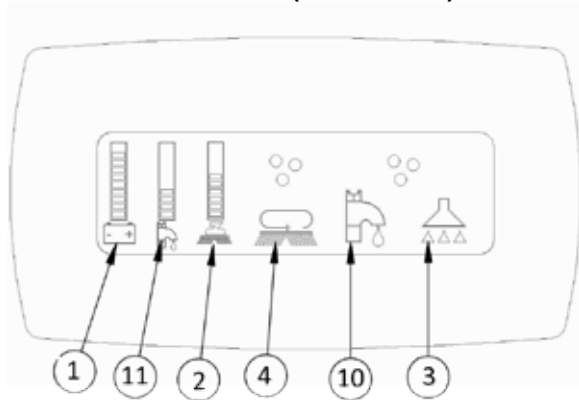

SCREEN #2 (MAINTENANCE)

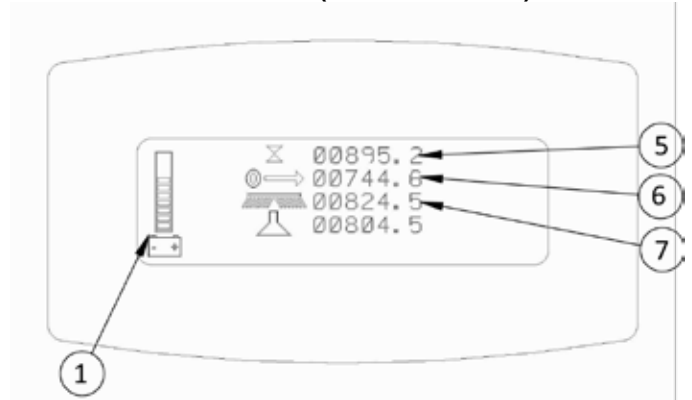

SCREEN #3 (WITH ERROR CODE)

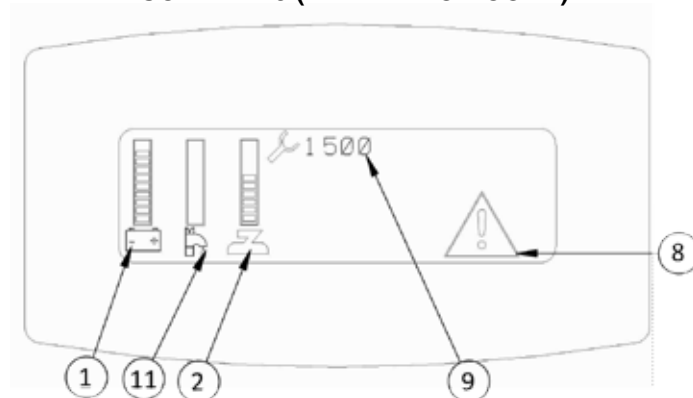

**** USE GREEN MENU SELECTION BUTTON ON CONTROL PANEL TO CHANGE SCREENS ****

1. **BATTERY LEVEL INDICATOR** - Indicates the energy level remaining in the batteries (*Shown on all menu displays*)
2. **SCRUBDECK DOWN PRESSURE GAUGE** - Sets the down pressure on the brushes
3. **VACUUM ON** - Indicates the vacuum is *ON*
4. **SCRUB MOTORS ON** - Indicates the brush motors are “running”
5. **KEY SWITCH HOUR METER** - Indicates the total number of hours that the machine has been *ON*
6. **SCRUB BRUSH HOUR METER** - Indicates the total number of hours that the brush motors have been used
7. **TRANSPORT HOUR METER** - Indicates the total number of hours the drive system has been used
8. **ERROR WARNING SYMBOL** - Indicates when there has been a diagnostic code error
9. **DIAGNOSTIC CODE** - When the machine has detected an error, it will display the warning symbol and a diagnostic code which tells you what’s wrong
10. **WATER ON** - Indicates the solution flow is *ON*
11. **SOLUTION LEVEL** - Indicates the gallons per minute (GPM) 0 - 1.0

MACHINE SETUP

UN-CRATING MACHINE:

Carefully check the crate for any signs of damage and that the batteries are in the unit.

To un-crate the machine, remove banding strips from around the crate. Take off the top and sides and dispose properly. Remove brackets from machine wheels. Remove bolts from pallet, then remove board. Carefully roll the machine off of the base. Notify the carrier immediately if concealed damage is discovered.

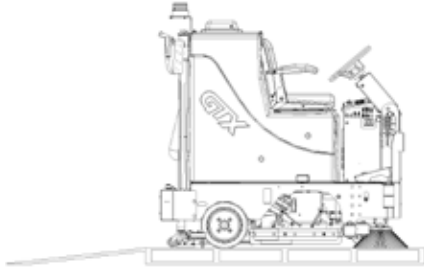

CONNECTING BATTERIES:

Your machine is equipped with (6x) 6-Volt/ 245 AH, (6x) 6-Volt/ 325 AH, or (6x) 6-Volt/ 360 AH Wet Lead Acid, AGM, or Deep Cycle Batteries which form a 36 Volt system.

(SEE PICTURE BELOW OR BATTERY DISCONNECT LABEL FOR CORRECT CABLE CONNECTIONS)

1. Turn all switches to the *OFF* position and remove Key.
2. Tip Tank back. Attach all Battery Cables to Terminals as shown below.
3. Turn *ON* main power switch and check the LCD to ensure correct installation. Charge Batteries if needed **(SEE BATTERY CHARGING)**.

NOTICE

Batteries are a possible environmental hazard. Consult your Battery supplier for safe disposal methods.

NOTICE

Orientation of Batteries is critical for cables to reach.

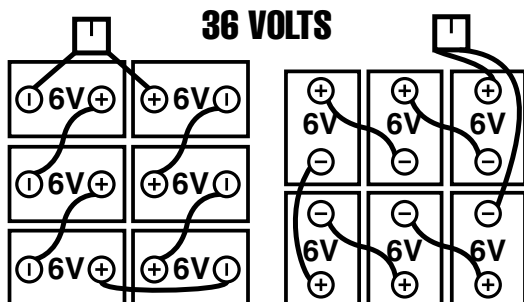

ATTACHING SQUEEGEE:

1. Lower the Squeegee Mounting Plate by depressing the Squeegee Lift switch **(A)** **(SEE BELOW)**.

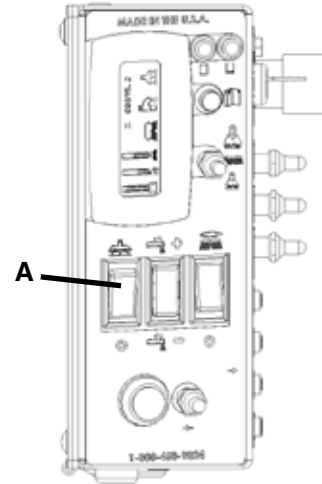

2. Loosen the two knobs **(B)** on the Squeegee and slide them into the slots in the Squeegee Mounting Plate **(SEE BELOW)**.

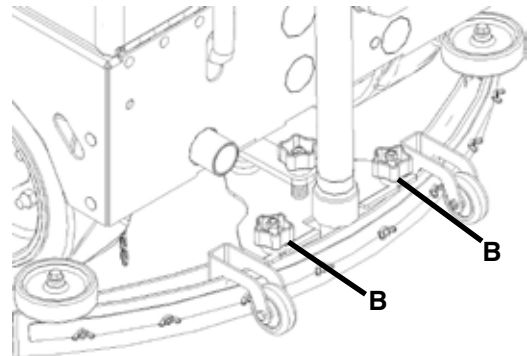

3. Tighten the two knobs and connect the Vacuum Hose **(C)** from the machine to the Squeegee **(SEE BELOW)**.

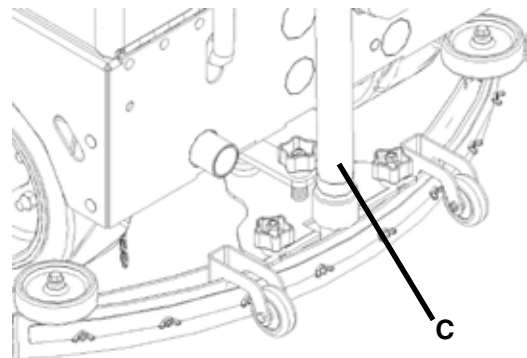

4. You may have to adjust the Squeegee Pitch **(SEE ADJUSTING SQUEEGEE ON THE NEXT PAGE)**

ADJUSTING SQUEEGEE:

1. Turning adjustment knob **(A)** clockwise (*tightening*) will lower tips and raise the center of the Squeegee (**SEE BELOW**).

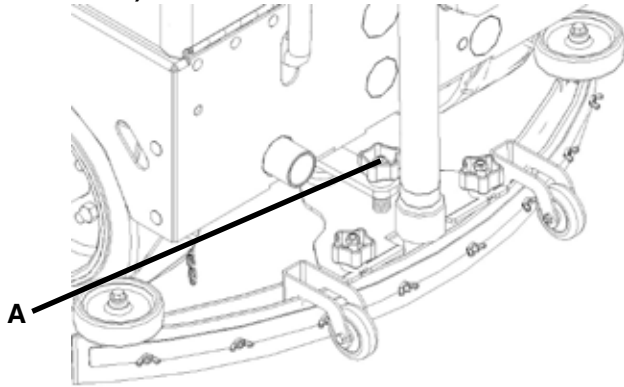

2. This Squeegee is adjusted too far back and will not pick up on the corners (**SEE BELOW**).
NOTE: Tips off of the floor.

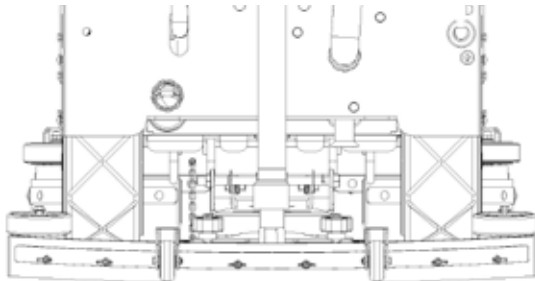

3. This Squeegee is adjusted too far forward and will not pick up in the center (**SEE BELOW**).
NOTE: Center spaced off the floor.

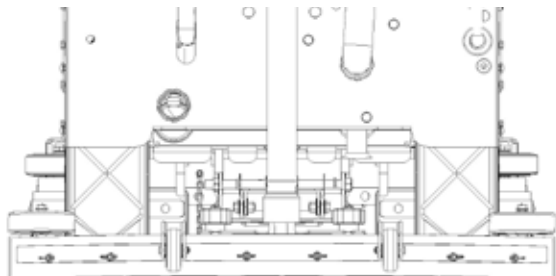

4. This Squeegee is adjusted just right with good deflection across the entire rear blade (**SEE BELOW**).

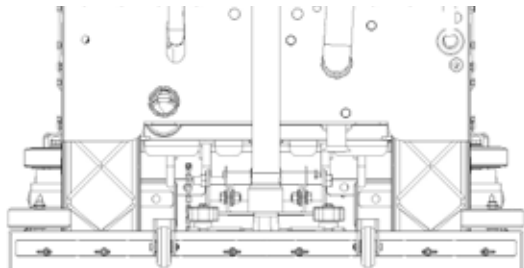

REMOVING SQUEEGEE:

1. With the Squeegee in the up position, turn machine power **OFF**.
2. Disconnect Vacuum Hose **(A)** from Squeegee and loosen both knobs **(B)** (**SEE BELOW**).

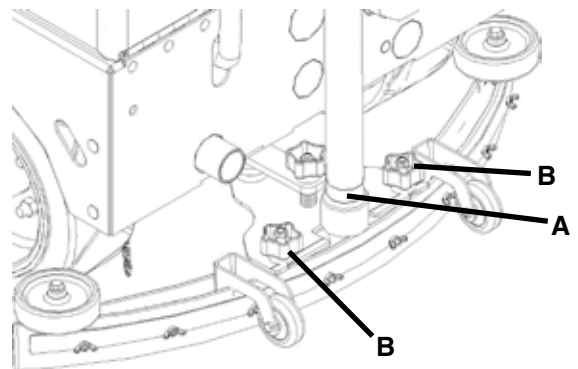

3. Pull Squeegee assembly backward from the lifting carrier.
4. Inspect or repair as needed and reinstall.

REPLACING OR ROTATING SQUEEGEE BLADES:

NOTICE

FOR SAFETY: Before leaving or servicing the machine, stop on a level surface, turn off machine and remove key.

1. Remove the Squeegee Assembly from the machine. Remove Blade retainer strap and remove Squeegee Blade.
2. Rotate the Squeegee to new edge position or replace as required.
3. Install Blade on the locating pins of Squeegee Assembly.
4. Install Squeegee Retainer Strap.
5. Fasten and lock knobs, starting in the center and moving outwards.

INSTALLING DISK PAD DRIVER OR BRUSH:

1. Turn *ON* machine power.
2. Raise the Scrubdeck by depressing the Brush switch to the up and *OFF* position and turn the machine power back *OFF*. Remove Key.
3. Loosen Star Knobs (**A**) and remove Shrouds to access the Scrubdeck (**SEE BELOW**).

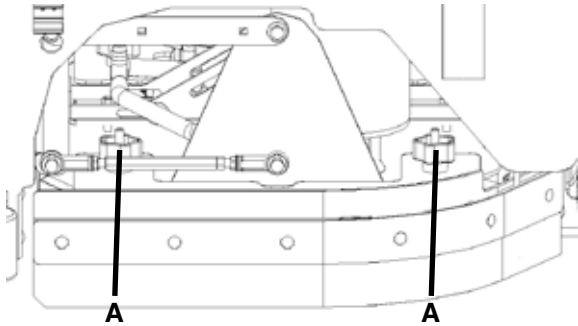

4. If the machine is equipped with a Shroud, unscrew Shroud Star Knobs (**C**) and pull Shroud forwards - Away from the front of the Scrubdeck (**SEE BELOW**).

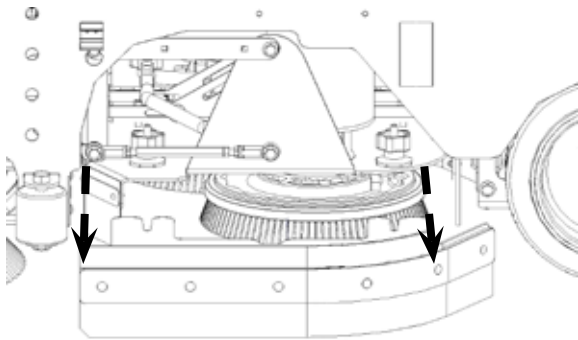

5. Attach Brushes or Pads to Motor Drives. Squeeze the scissor locking device and lift brush up on to the motor drive hub. Make sure the scissors close and lock on the brushes (**SEE BELOW**).

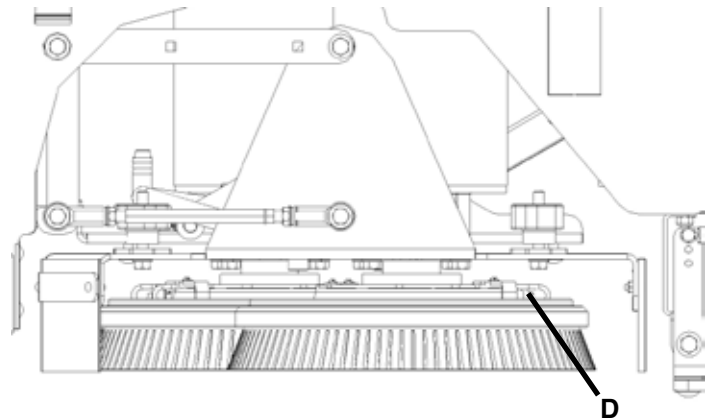

INSTALLING DRIVER PADS:

1. Select the correct Pads that best meet your cleaning application needs. Consult your local dealer for assistance.
2. Pad Installation: Attach Pads to Pad Drivers before connecting drivers to motor hub. Screw center clip (**E**) into place (**SEE BELOW**).

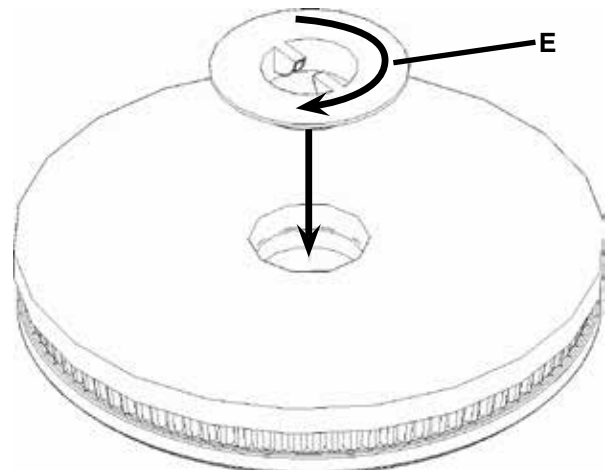

SCRUB BRUSHES / PADS:

There are many different types of brushes available to cover applications from cleaning heavily soiled floors to polishing. A Pad Driver is also available to take advantage of the many cleaning pads on the market. Please refer to the “**Common Wear Parts**” page to assist in selecting the proper Brush / Pad for the work at hand.

INSTALLING CYLINDRICAL BRUSH:

1. Turn *ON* machine power.
2. Raise the Scrubdeck by depressing the Brush switch to the up and *OFF* position and turn machine power back off. Remove Key.

CAUTION

Disconnect the batteries.

3. Remove Side Wiper pin (**A**) and open the Wipers outward to allow access to the Cylindrical Door (**B**) (**SEE BELOW**).

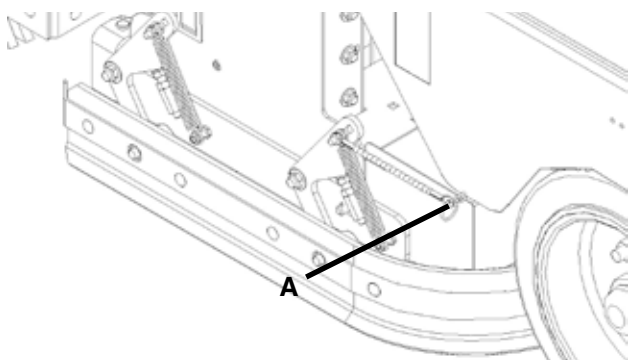

4. Press Side Door Latch (**C**) and pull door off of Scrubdeck to allow access to the brushes (**SEE BELOW**).

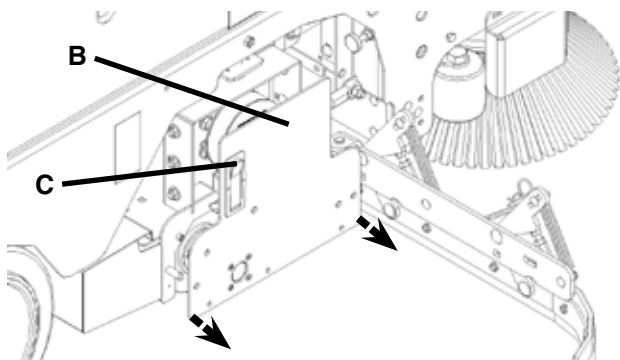

5. Slide Brush (**D**) into Brush area and engage onto the Brush Driver on the opposite side (**SEE BELOW**).

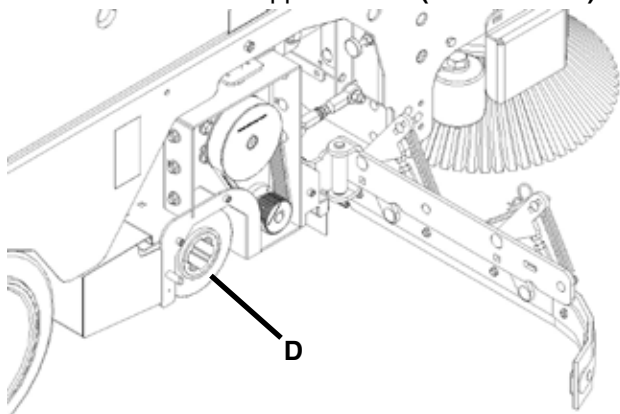

6. With Brushes engaged, re-attach the Side Door as well as the Side Wipers.

NOTICE

If the Brushes are not fully engaged with the Drivers, the Brushes will be damaged. Do **NOT** force the access door back on. This usually indicates improper Brush installation.

7. Brush drivers shown misaligned (**SEE BELOW**).

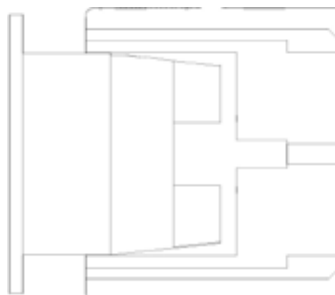

OLD STYLE DRIVER

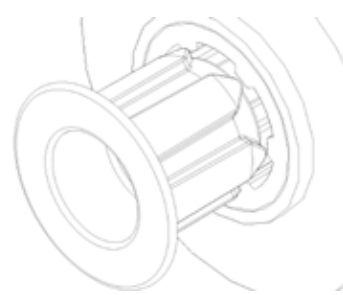

NEW STYLE DRIVER

8. Brush driver shown properly aligned (**SEE BELOW**).



OLD STYLE DRIVER

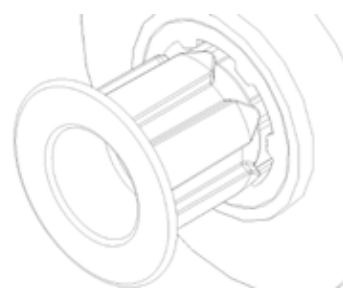

NEW STYLE DRIVER

INSTALLING EDGE PADS:

1. Turn *ON* machine power.
2. Raise the Scrubdeck by depressing the Brush switch to the *UP* and *OFF* position and turn machine power back off. Remove Key.
3. Select the correct Pads that best meet your cleaning application. Consult your local dealer for assistance.
4. Remove the EDGE Scrubdeck shrouds by turning the Rubber knobs and sliding the shroud off (**SEE BELOW**).

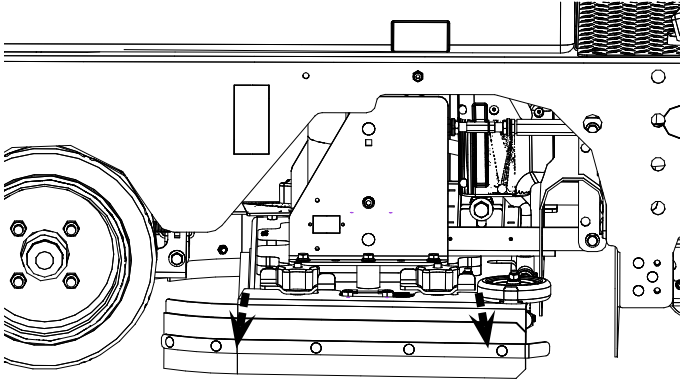

5. Remove any Pad previously attached to the EDGE Grip Face by pulling down from the corners (**SEE BELOW**).

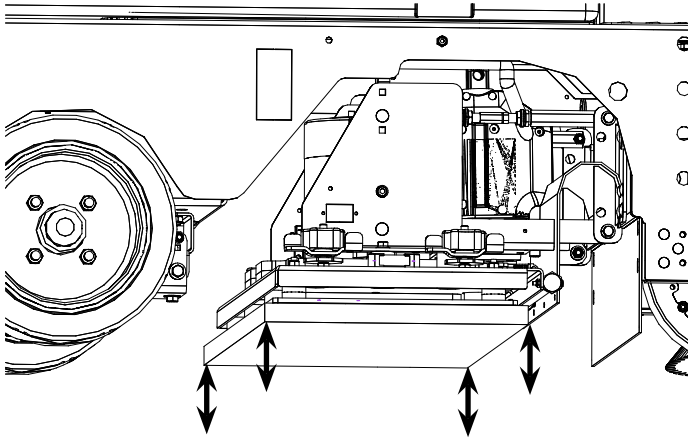

6. Once Grip Face is clear of any Pads, place pad wanted for application centered on the Grip Face (*This will leave a 1/2" overhang on all sides*).
7. Press upwards on the Pad to secure it in place (**SEE ABOVE**).
8. With Pad attached securely to Grip Face of EDGE Deck, the machine is ready to use.

LEVELING EDGE DECKS:

NOTICE

All Scrubdeck's should be level at time of machine delivery. If machine Scrubdeck is not level - Contact your Servicing Dealer.

1. Drive machine to a flat level surface and turn machine *OFF*.
2. Ensure that Scrubdeck is in full upright position.
3. Turn *ON* machine and depress the brush switch. Just before the Scrubdeck's EDGE Pad touches the ground, turn machine *OFF*.
4. Loosen the Locking Nut (**A**) on the Adjustable Deck Arms. Turn the Hexagonal Arm (**B**) on each side of the Scrubdeck to level it. Use the Scrubdeck Levels (**C**) built into the deck (**SEE BELOW**).

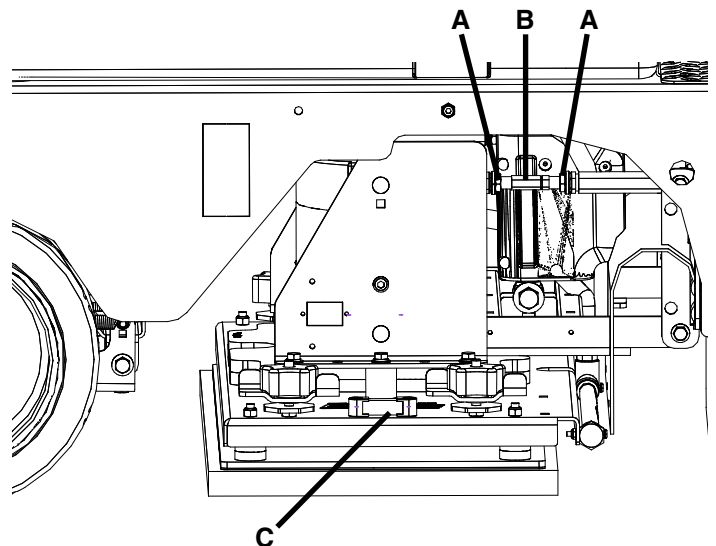

5. Extending the Adjustable Arms raise the front and lowers the rear of the Scrubdeck. After Scrubdeck has been leveled - tighten Locking Nuts (**A**).

NOTICE

NEVER place aggressive Pads (Maroon Prep, Dominator HD Strip, etc.) directly onto the Grip Face. Always use Red or Blue Spacer pad to prevent Grip Face damage.

LEVELING DISK DECKS:

NOTICE

All Scrubdeck's should be level at time of machine delivery. If machine Scrubdeck is not level - Contact your Servicing Dealer.

1. Drive machine to a flat level surface and turn machine off.
2. Ensure that Scrubdeck is in full upright position. Remove Shrouds **(A)** by loosening Star Knobs **(B)** and pulling away from Scrubdeck **(SEE BELOW)**.

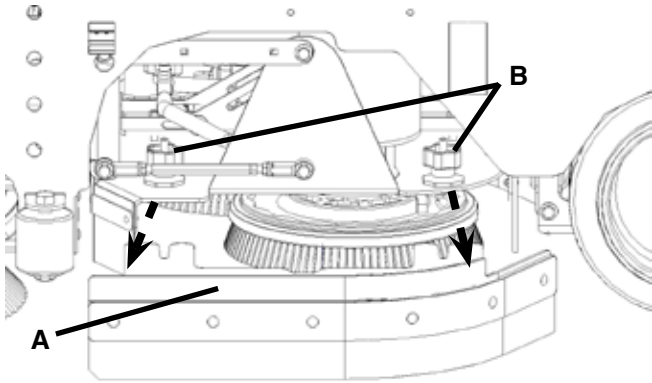

3. Turn **ON** machine and depress the Brush switch. Just before the Scrubdeck's Brushes touch the ground, turn machine **OFF**.
4. Loosen the Locking Nut **(C)** on the Adjustable Deck Arms. Turn the Hexagonal Arm **(D)** on each side of the Scrubdeck to level it **(SEE BELOW)**.

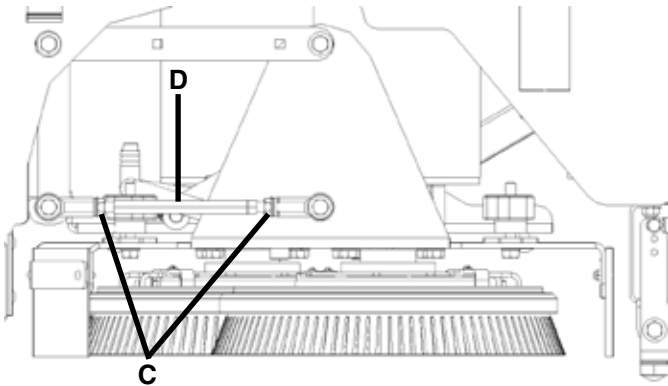

5. Extending the Adjustable Arms raise the front and lowers the rear of the Scrubdeck. After Scrubdeck has been leveled (*ensure correct pitch backward - if you have*) - retighten Locking Nuts **(C)**.

LEVELING CYLINDRICAL DECKS:

NOTICE

All Scrubdeck's should be level at time of machine delivery. If machine Scrubdeck is not level - Contact your Servicing Dealer.

1. Drive machine to a flat level surface and turn machine off.
2. Ensure that Scrubdeck is in full upright position and remove brushes.
3. Turn **ON** machine and depress the Brush switch. Just before the Scrubdeck touches the ground, turn machine **OFF**.
4. Loosen the Locking Nut **(A)** on the Adjustable Deck Arms. Turn the Hexagonal Arm **(B)** on each side of the Scrubdeck to level it. Use the levels built into the deck **(SEE BELOW)**.

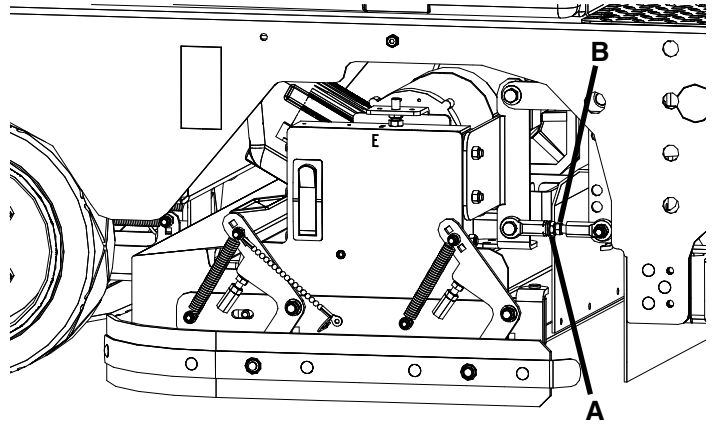

5. Extending the Adjustable Arms raise the front and lowers the rear of the Scrubdeck. After Scrubdeck has been leveled - retighten Locking Nuts **(A)**.

MACHINE OPERATION

PRE-CLEANING CHECKLIST:

Read and understand the Safety Messages section on Pages 3 and 4 before operating the machine.

1. Check Battery Condition Gauge on the Control Panel. Make sure Batteries are fully charged before using.
2. Check the condition of the Pads or Brushes.
3. Check the condition of the Squeegee Blades.
4. Raise the Scrubdeck and Squeegee before transporting then transport the machine to the filling station.
5. Turn the machine *OFF*.
6. Fill the Tank with up to 30 gallons of clean water either at the fill port **(A)** (SEE BELOW).
7. Add **APPROVED** cleaning chemical to the Tank. Use the proper dilution ratio indicated on the bottle. Contact us at 1(800)-634-4060 or +011-262-681-3583 if unsure.

NOTICE

The clear tube (*Solution Sight Tube*) **(B)** at the rear of the machine indicates the amount of water in the Tank **(SEE BELOW)**.

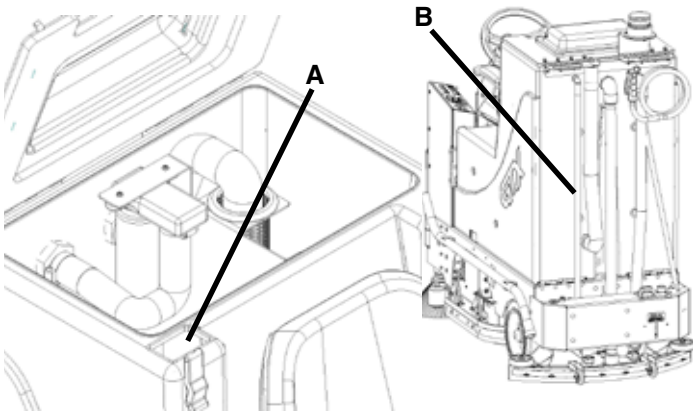

OPERATING HINTS:

1. Observe the amount of solution the machine is dispensing on the floor and adjust to the desired flow. To increase the solution flow rate, press the Solution Control Switch up. To shut the solution *OFF* completely, just release the Foot Pedal, or use dash mounted switch.
2. Keep an eye on the clear Vacuum cover to make sure that there is not any foamy buildup in the Recovery Tank. If excess foam begins to develop, pour a recommended foam control solution into the Recovery Tank. Foam is usually an indication of excessive soap.
3. Always operate at lower speeds when scrubbing around walls and objects. You should reduce the speed to maintain control when turning.
4. If Squeegee starts to streak, raise and wipe the Blades with a clean cloth. If the problem continues, check the Squeegee Blades for wear or damage and rotate if needed. You may need to pre-sweep before scrubbing. **(Only Use OEM Parts)**
5. Change or turn over Brushes / Pads when dirty.
6. Stay clear of objects protruding from the floor such as sockets, grates, etc, for they will damage the Brushes / Pads and Squeegee Blades.
7. Always keep an eye on your gauges. They let you know the status of a particular system at a glance. If your battery gauge is reading low you must stop immediately and recharge. Running the Batteries dead will result in damage to the Batteries.
8. When you run out of solution, raise the Scrubdeck and continue to Vacuum the remaining water until it is all consumed. The Solution Sight Tube is used to indicate the level of detergent remaining in the Tank.
9. When you are ready to stop, raise the Scrubdeck, turn *OFF* the solution switch, raise the Squeegee and drive the machine back to the charging area. Be sure to drain both Tanks before storing the machine.

⚠ DANGER

EXPLOSION RISK! Flammable materials can cause an explosion or fire. Do NOT use flammable materials in Tank or pick up.

⚠ CAUTION

TO AVOID DAMAGE TO THIS MACHINE:

- Use APPROVED detergents only
- Water temperature must not exceed 130°F/54°C
- Do NOT use high-percentage Bleach mixture

ONE PASS SCRUBBING:

1. Turn on machine Key Switch **(A)**.
2. Lower the Squeegee by depressing the Squeegee Switch **(G)** (*Vacuum Motor will turn on automatically*).
3. Lower Scrubdeck head to the floor by pressing the Scrubdeck Switch on the Control Panel **(D)**.
4. Press up or down on the Solution Flow Switch **(C)** to regulate the amount of solution flow.
5. Begin scrubbing by depressing the Foot Pedal **(H)** slowly and then to the speed required.
6. Once the machine begins to move, check the down pressure on the LCD screen. To adjust the down pressure, push toggle switch **(B)** forward to increase pressure backward to decrease pressure. Start scrubbing at the #1 or #2 marks. Do not use the #4 or #5 marks without management's approval.
7. To operate the machine in reverse, simply switch the Reverse switch **(E)** back towards the rear of the machine. The reverse speed is set to approximately 50% of the forward speed.
8. To stop the machine, release the Foot Pedal and the machine will stop automatically **(H)**.
9. Depressing the green Uni-Touch button **(F)** activates the Scrubdeck, Vacuum, and Squeegee simultaneously.

SCRUB ONLY:

1. Turn on machine Key Switch **(A)**.
2. Lower Scrubdeck head to the floor by pressing the Scrubdeck Switch on the Control Panel **(D)**.
3. Press up or down on the Solution Flow Switch **(C)** to regulate the amount of solution flow.
4. Begin scrubbing by depressing the Foot Pedal **(H)** slowly and then to the speed required.
5. Once the machine begins to move, check the down pressure on the LCD screen. To adjust the down pressure, push toggle switch **(B)** forward to increase pressure backward to decrease pressure. Start scrubbing at the #1 or #2 marks. Do not use the #4 or #5 marks without management's approval.
6. To operate the machine in reverse, simply switch the Reverse switch **(E)** back towards the rear of the machine. The reverse speed is set to approximately 50% of the forward speed.
7. To stop the machine, release the Foot Pedal and the machine will stop automatically **(H)**.

VACUUM ONLY:

1. Turn on machine Key Switch **(A)**.
2. Lower the Squeegee by depressing the Squeegee Switch **(G)** (*Vacuum Motor will turn on automatically*).
3. Begin vacuuming by depressing the Foot Pedal **(H)** slowly and then to the speed required.
4. To stop the machine, release the Foot Pedal and the machine will stop automatically **(H)**.

ADJUST SOLUTION FLOW:

1. Push UP (+) on the Solution Flow switch **(C)** to increase the solution flow and push DOWN (-) on the toggle to decrease solution flow (**SEE BELOW**).

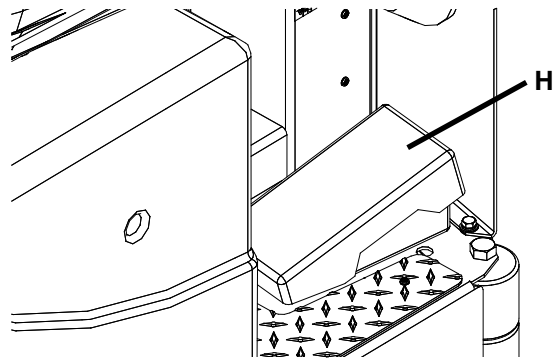
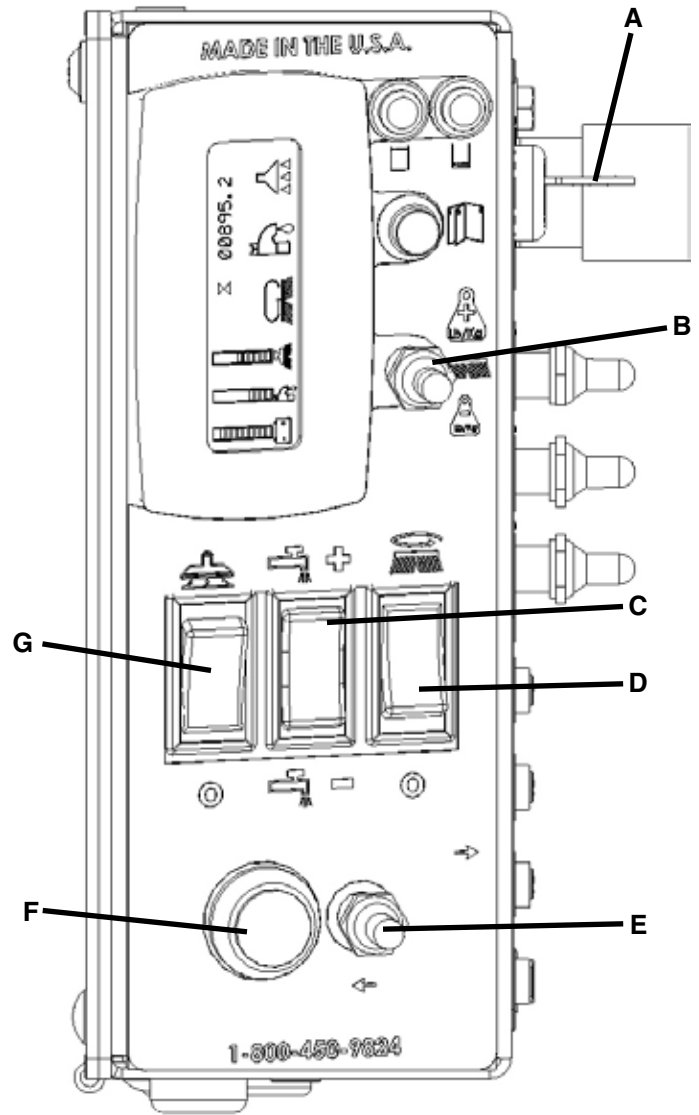

ADJUST SHROUDS BLADES:

1. For Shroud rubber adjustments, loosen the Nylok Nuts (**A**) on the back of the Shrouds (**SEE BELOW**).
2. To adjust rubber to the desired height, just slide the curtain up or down in the slits and tighten screws.
3. Reattach the Shroud to the Scrubdeck by sliding back on and tightening the Star Knobs.

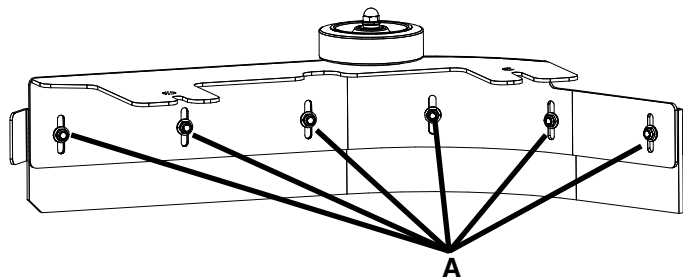

ADJUST WIPERS BLADES:

1. For Cylindrical side Wipers, open wipers by releasing the pin. Loosen Wiper band screws (**B**) (**SEE BELOW**).
2. To adjust Wiper to the desired height, just slide the Wiper up or down in the slots and tighten the screws.

FRONT:

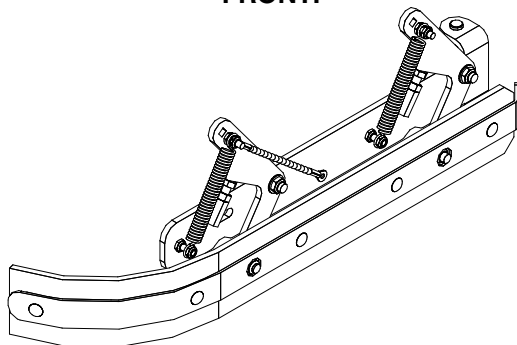

BACK:

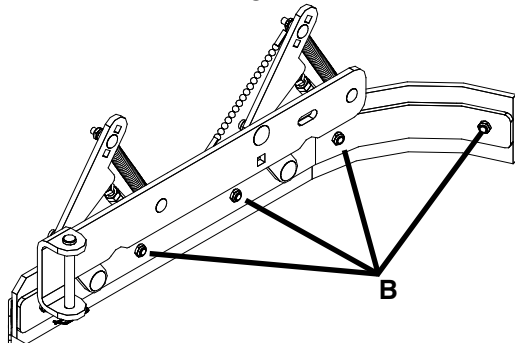

ADJUST SHROUDS:

1. For Shroud adjustments, loosen the Start Knobs (**C**) and remove Shroud (**SEE BELOW**).

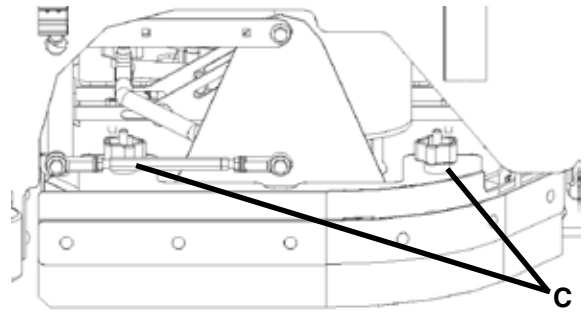

2. Spin the Red Shroud Adjustment Knobs (**D**) up or down on the Shroud Support Bolt (**SEE BELOW**).

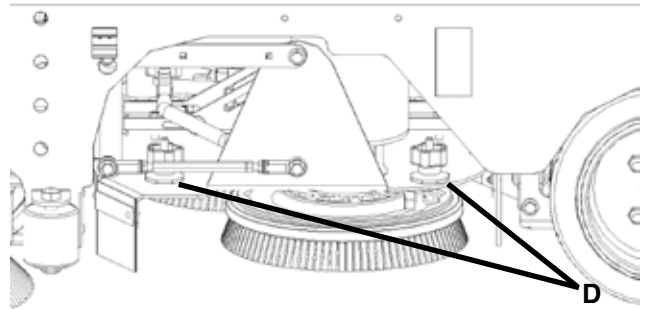

3. Once adjusted to the proper height, tighten shrouds back in place.

ADJUST CYLINDRICAL WIPERS:

1. To adjust the Wiper Blades on a Cylindrical Scrubdeck machine, first loosen the locking nut (**E**) (**SEE BELOW**).

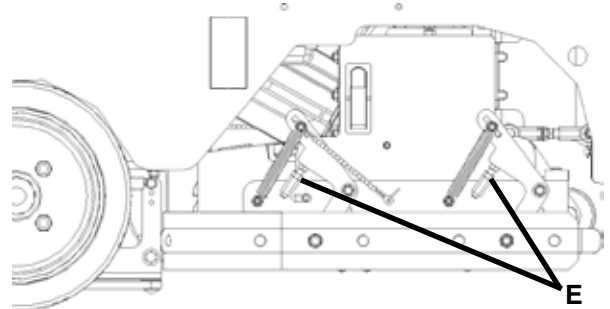

2. Turn the adjustment screw (**F**) in to raise the wipers or out to lower the wipers. The spring (**C**) provides tension during adjustment (**SEE BELOW**).

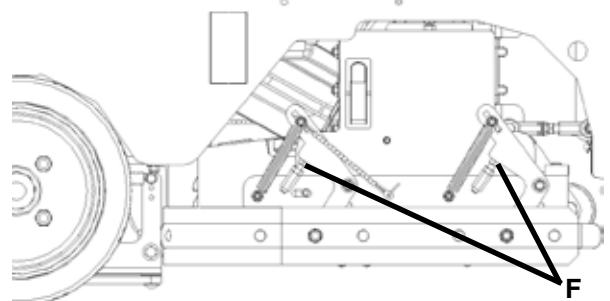

OPEN RECOVERY LID:

1. Release both latches **(A)** on Recovery Tank lid **(SEE BELOW)**.
2. Rotate lid fully open.

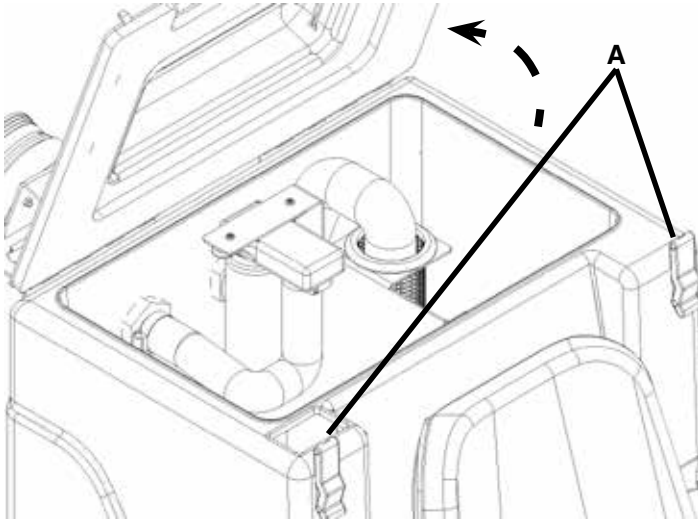

FLUSH RECOVERY TANK:

1. Rinse the Recovery Tank after every use **(B)**. This will prevent heavy build-up on the bottom of the tank, foul odors as well as clogging of the Drain Hose **(SEE BELOW)**.

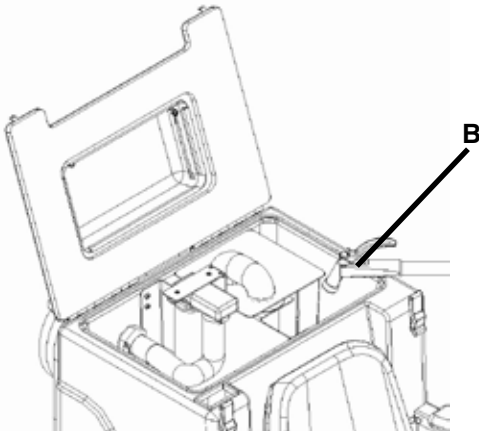

2. Remove Drain Hose **(C)** and open to allow for drainage of the Recovery Tank **(SEE BELOW)**.

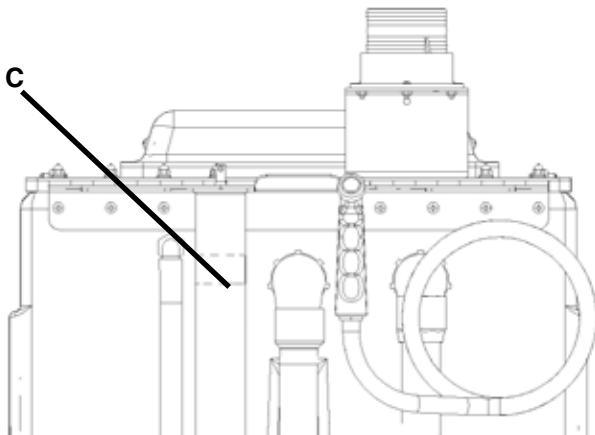

3. Flush Recovery Tank with water hose.
4. After rinsing, reattach the Drain Hose **(C)** on hook **(SEE ABOVE)**.

NOTICE

Keep water off of Control Panel.

CLEAN "DRAIN SAVER":

With Recovery Lid open and Tank fully drained:

1. Remove 2" Squeegee Intake Hose **(D)** from "Drain Saver" strainer **(E)** **(SEE BELOW)**.
2. Remove stainless screen and dispose of debris.
3. Rinse screen with fresh water from the outside while holding the screen upside down. This will allow for better cleaning.
4. Replace the screen into the bracket.
5. Replace 2" Squeegee Intake Hose.

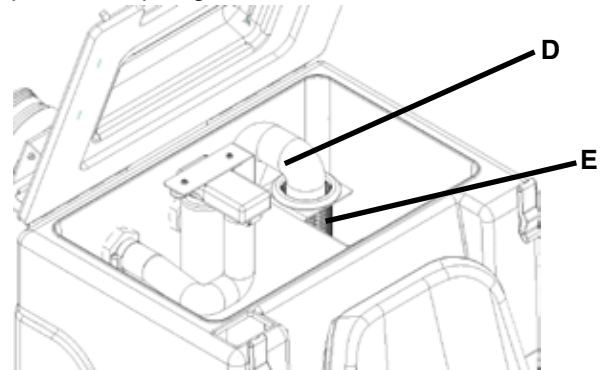

CLEAN VACUUM SCREEN:

With Recovery Lid open and Tank fully drained:

1. Remove Vacuum Screen retaining clip **(F)** **(SEE BELOW)**.
2. Pull Vacuum Screen and float ball assembly **(G)** off of the Vacuum Box.
3. Rinse with hot water.
4. Dry thoroughly.
5. Replace the Vacuum Screen onto box.
6. Replace and tighten retaining clip.

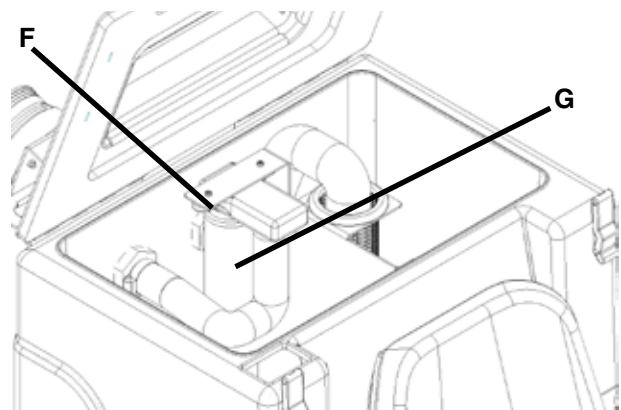

SOLUTION FILTER:

The solution system has an "Inline Filter" (**A**) to filter out cleaning solution prior to scrubbing (**SEE BELOW**).

CLEANING SOLUTION FILTER:

1. To clean the Solution Filter, tip tank and then close Gate Valve (**B**) (**SEE BELOW**).

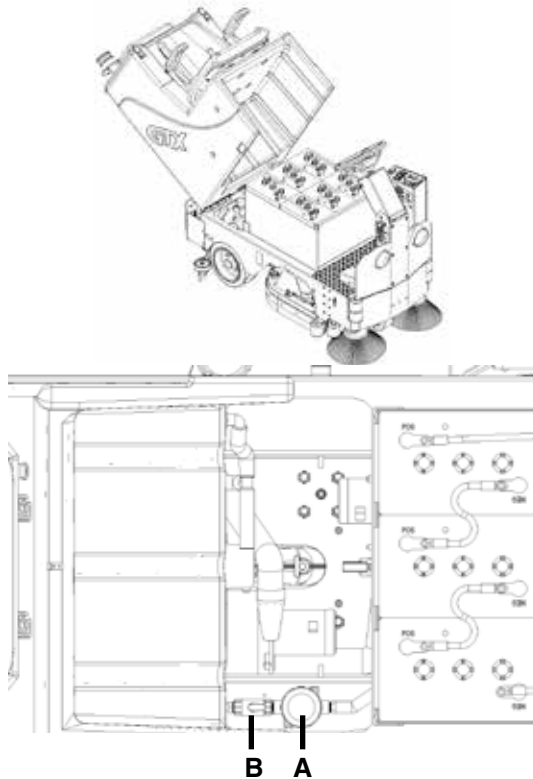

2. Unscrew the clear cap (**C**) from house (**D**) and remove the stainless steel screen (**E**) (**SEE BELOW**).

3. Rinse any debris from the screen with clean water.

4. Reinstall screen and screw cap back on tightly.

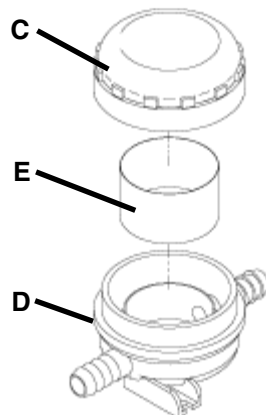

SQUEEGEE UP:

1. To raise the Squeegee off the floor, press the Squeegee Vacuum Lift switch (**C**) down (**SEE BELOW**).

SQUEEGEE DOWN:

1. To lower the Squeegee to the floor, press the Squeegee Vacuum Lift switch (**C**) up (**SEE BELOW**). Use with remote Vacuum Wand.

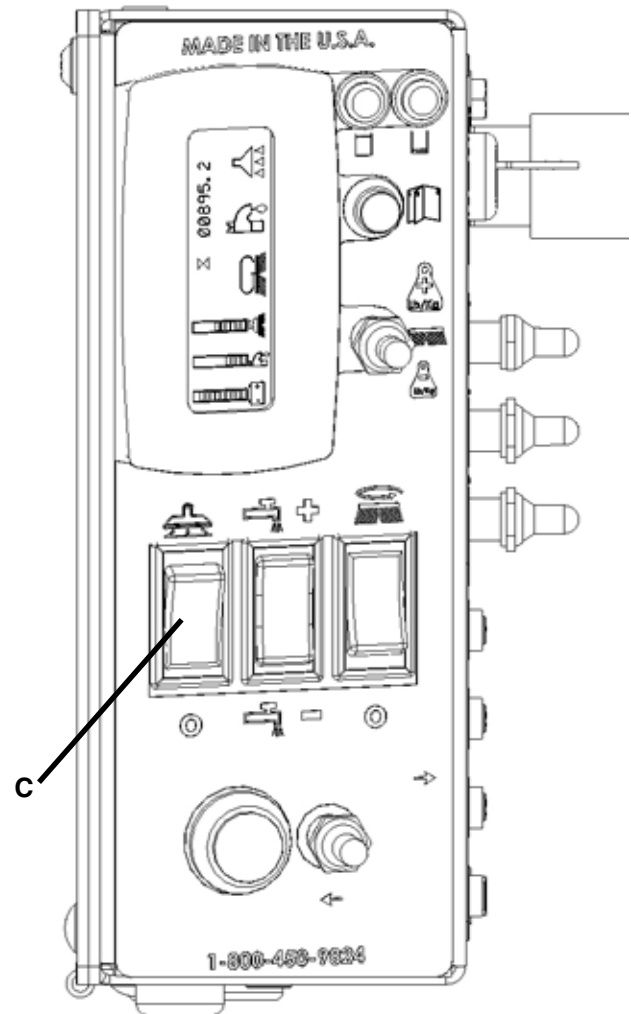

DRAINING SOLUTION TANK:

To drain unwanted cleaning solution from the Solution Tank, perform the following steps:
(SEE BELOW)

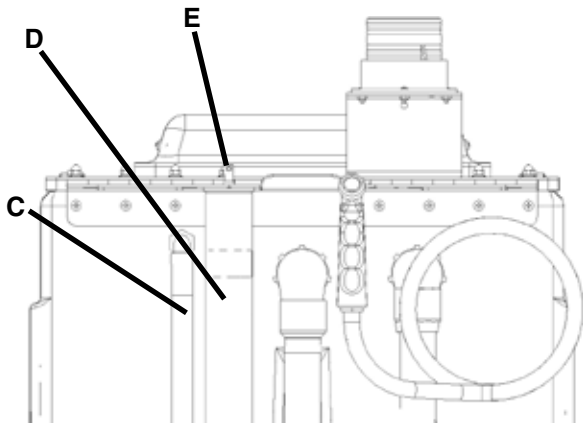

1. Tip machine Tank back and pull the clear Sight Tube/Drain Hose (**C**) off barbed fitting.
2. Rinse out Tank and solution flow system with clean water.

DRAINING RECOVERY TANK:

Always empty Recovery Tank when refilling the Solution Tank. You can refill the Solution Tank while the Recovery Tank is draining.

1. To drain the Recovery Tank remove Drain Hose (**D**) by loosening the Recovery Hose Gasket (**E**) at the rear of the Tank and tip down (**SEE ABOVE**).

NOTICE

Leave Recovery Lid open while draining Tanks. Rinse thoroughly.

NOTICE

Get Supervisor APPROVAL first and drain at APPROVED locations only.

RELEASING PARKING BRAKE OVERRIDE LEVER:

To release the Parking Brake, move the Parking Brake Override Lever (**F**) to the UP position. To return back to Override Mode - slide to the DOWN position.

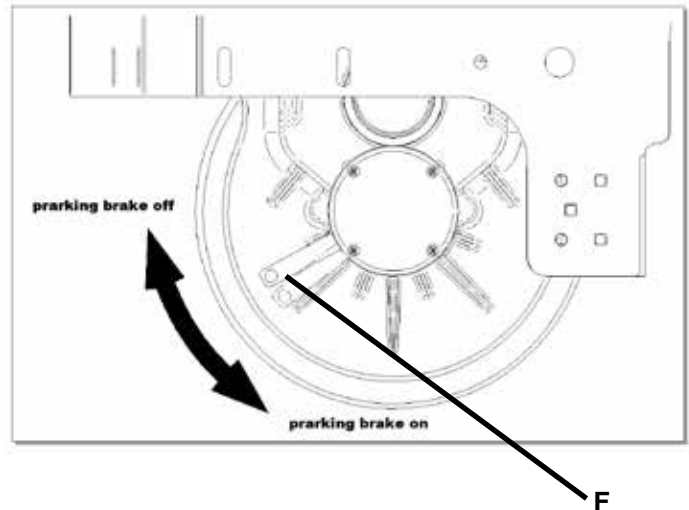

BATTERY CHARGING

Charger Specifications

- Output voltage of 36 Volts
- Output current of 36 amps max (*Optional*)
- Input voltage of 110 Volts/ 60 Hz (*220V/50 Hz available*)
- Automatic shut off circuit
- Made for Deep Cycle Batteries

⚠ DANGER

Explosive hydrogen gas forms when Batteries are charging. An open flame or spark can cause this gas to explode. Serious personal injury or property damage could occur. Only charge the Batteries in this machine in a well ventilated area.

⚠ WARNING

Before you service a Battery, always wear face protection, protective gloves and protective clothing. Battery acid or battery explosion can cause serious injuries.

⚠ WARNING

The Batteries in this machine contain sulfuric acid, which causes burns to skin. If battery acid contacts clothing or skin, rinse the effected area with cold water immediately. If battery acid gets on your face or in your eyes, flush the area immediately with cold water and seek medical attention.

⚠ CAUTION

Always use the automatic battery charger provided by the manufacturer of this machine to charge the Batteries of this machine. It is designed to charge the Batteries at the appropriate rate. If you must use a different charger, disconnect the Batteries before charging to avoid damage to the electronic speed controller.

EXTERNAL BATTERY CHARGING:

1. Transport machine to a well ventilated area for charging.
2. Turn the machine off. Tip Tank back.
3. Check the water in each Battery (**A**). Do not charge the machine unless the water is slightly higher than the plates. If needed, add enough distilled water to just slightly cover the plates. Be careful not to over fill. Batteries can overflow during charging. Replace caps before charging.
4. First, plug the red 50 Charger plug into the machine's Charger Port (**B**). While the Charger plug

is connected, plug the charger power cord into a grounded 110 Volt standard wall outlet (**C**).

5. The Charger will automatically begin charging and automatically shut off when fully charged (*check Battery gauge*).
6. After the Charger has turned off - First, unplug the Charger from the wall outlet. Second, unplug the red 50 Charger plug from the machine.
7. Recheck the cell level after charging. If needed, add distilled water up to the correct level. Be certain to replace the caps securely and to wipe off the top of the Batteries with a clean cloth.

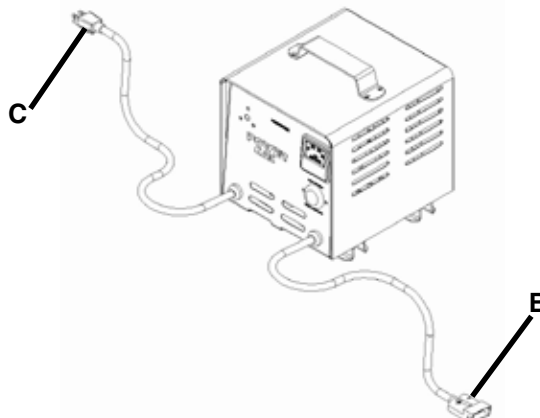
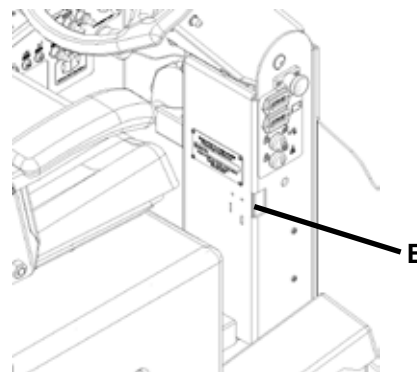
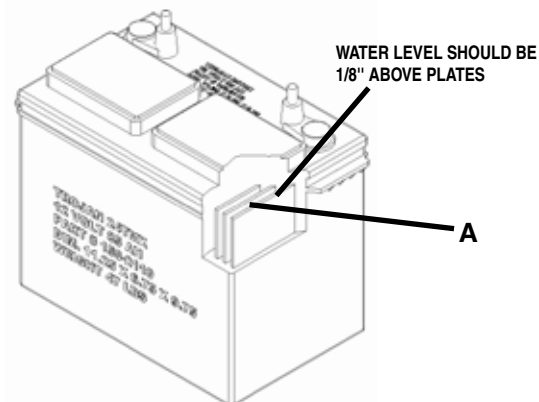

ON-BOARD CHARGER

Charger Specifications

- Output voltage of 24 Volts
- Output current of 12 amps max
- Input voltage of 110 Volts/ 60 Hz
(220V/50 Hz available)
- Automatic shut off circuit
- Made for Deep Cycle Batteries

⚠ DANGER

Explosive hydrogen gas forms when Batteries are charging. An open flame or spark can cause this gas to explode. Serious personal injury or property damage could occur. Only charge the Batteries in this machine in a well ventilated area.

⚠ WARNING

Before you service a Battery, always wear face protection, protective gloves and protective clothing. Battery acid or battery explosion can cause serious injuries.

⚠ WARNING

The Batteries in this machine contain sulfuric acid, which causes burns to skin. If battery acid contacts clothing or skin, rinse the effected area with cold water immediately. If battery acid gets on your face or in your eyes, flush the area immediately with cold water and seek medical attention.

⚠ CAUTION

Always use the automatic battery charger provided by the manufacturer of this machine to charge the Batteries of this machine. It is designed to charge the Batteries at the appropriate rate. If you must use a different charger, disconnect the Batteries before charging to avoid damage to the electronic speed controller.

ON-BOARD BATTERY CHARGING (OPTIONAL):

1. Transport machine to a well ventilated area for charging.
2. Turn the machine off. Tip Tank back.
3. Check the water in each Battery **(A)**. Do not charge the machine unless the water is slightly higher than the plates. If needed, add enough distilled water to just slightly cover the plates. Be careful not to over fill. Batteries can overflow during charging. Replace caps before charging.

4. Plug the Charger power cord into a grounded standard wall outlet **(B)**.
5. The green Indicator Light **(C)** will come on and the Charger will automatically begin charging. When finished, the Charger will automatically shut off as well as the green indicator light (*check Battery gauge*).
6. After the Charger has turned off, unplug the Charger from the wall outlet.
7. Recheck the cell level after charging. If needed, add distilled water up to the correct level. Be certain to replace the caps securely and to wipe off the top of the Batteries with a clean cloth.

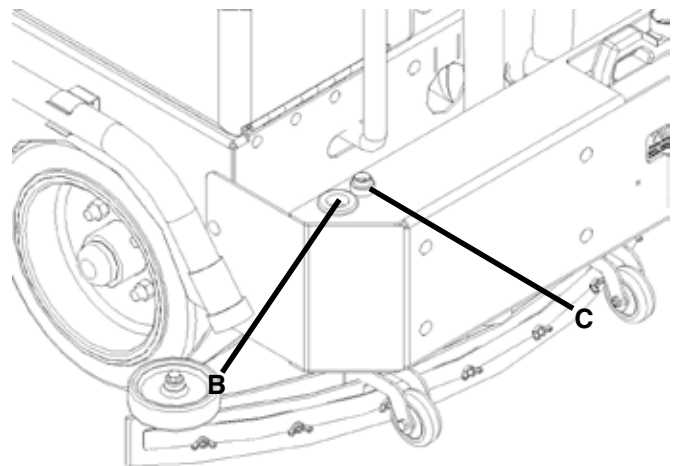
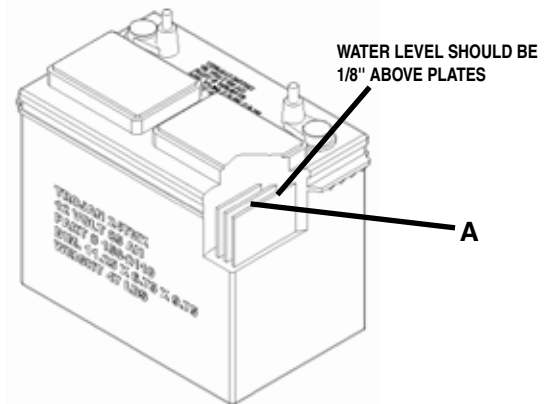

DESCRIPTION OF LED

- Red LED:* Battery level low
- Yellow LED:* Battery at 1/2 charge
- Green LED:* Battery fully charged

BATTERY MAINTENANCE GUIDE

SAFETY:

⚠ DANGER

Explosive hydrogen gas forms when Batteries are charging. An open flame or spark can cause this gas to explode. Serious personal injury or property damage could occur. Only charge the Batteries in this machine in a well ventilated area.

⚠ WARNING

Before you service a Battery, always wear face protection, protective gloves and protective clothing. Battery acid or battery explosion can cause serious injuries.

⚠ WARNING

The Batteries in this machine produce hazardous voltage which can cause electrical shock, burns and/or electrocution. Always disconnect Batteries before servicing this machine.

⚠ WARNING

The Batteries in this machine contain sulfuric acid, which causes burns to skin. If battery acid contacts clothing or skin, rinse the effected area with cold water immediately. If battery acid gets on your face or in your eyes, flush the area immediately with cold water and seek medical attention.

⚠ WARNING

Dress safely. Do not wear rings or metal wrist watches when servicing this machine, as they can cause an electrical short circuit which can cause serious burns.

WATERING:

- Add water, NEVER ACID, to cells (*distilled water recommended*).
- Do not over water
- Before charging the Batteries, only add water if the plates are exposed. Add just enough water to cover the plates, then charge the batteries. Once fully charged, add water to the proper level as indicated below.
- For full charge plus series Batteries add water to the maximum water level indicator (**A**).
- Water watering, secure vent caps back on Batteries.

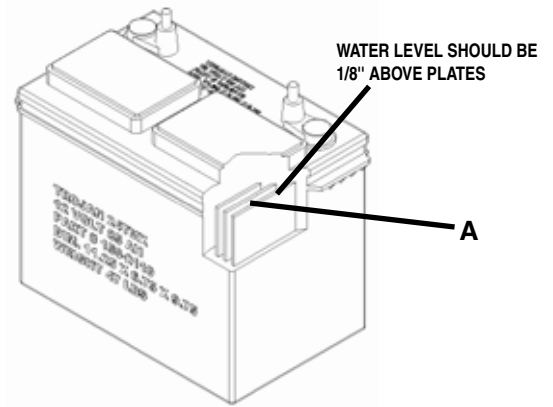

INSPECTION AND CLEANING:

- Keep Batteries clean and dry from residue
- Check that all vent caps are tight
- Use a solution of baking soda and water to clean if acid residue on Batteries or corrosion on the terminals
- Protective spray of petroleum jelly should be applied to terminals to reduce corrosion

STORAGE:

- Batteries should be fully charged prior to and during storage
- Never store discharged Batteries
- Store Batteries in a cool, dry place but never below freezing - Recharge in storage a minimum of every 30 days
- Recharge Batteries before putting them back into service

MAINTENANCE

DAILY MAINTENANCE:

1. Remove the clean Pads or Brushes. Never use soiled Pads when cleaning. Replace Pads when they become packed with residue.
2. Remove and clean debris from the float shut-off screen and Drain Saver located inside the Recovery Tank.
3. Drain and rinse Tanks thoroughly and flush out Solution Feed to deck.
4. Inspect Vacuum Hose for any objects obstructing the air flow.
5. Raise Squeegee and wipe Blades with a clean cloth. Store Squeegee in the raise position to prevent damage or setting of the Blades.
6. Wipe down machine if needed. Use a non-abrasive, non-solvent cleaner or a clean damp cloth.
7. Recharge the Batteries if needed.

WEEKLY MAINTENANCE:

1. Check Battery water level in each cell of the Batteries and fill as needed. Always use distilled water to refill Batteries. Batteries should be filled approximately ¾" to 1" above the plates. Overfilling will cause the Batteries to leak during charging. The charging process creates gas bubbles inside the Battery, which effectively increases the volume of the electrolyte.

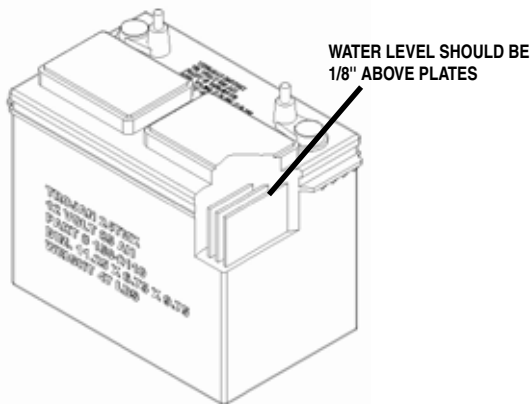

2. Clean Battery tops to prevent corrosion.
3. Flip Scrubdeck Brushes / Pads.
4. Drain and rinse tanks thoroughly. To thoroughly flush out any solution chemicals in solution line valves, refill solution tank with a few gallons of warm, clean water and run the machine until tank is empty.

MONTHLY MAINTENANCE:

1. Check Scrubdeck and Squeegee lifting cables for wear and spring tension.
2. Check machine for water leaks and loose nuts and bolts.
3. Check to see if Battery cables are tightened. Tighten,

if needed, 8-10 ft/lb MAX.

4. Grease caster swivel and Squeegee Pivot Point.

YEARLY MAINTENANCE:

Call your local dealer for yearly maintenance.

STORING MACHINE:

1. Be sure to flush the Tanks out completely. To thoroughly flush out any solution chemicals in solution line and valves, refill Solution Tank with a few gallons of warm clean water and run machine until Tank is empty.
2. Open the Recovery Tank lid to promote air circulation.
3. Raise Scrubdeck and Squeegee.

CHECKING BATTERY SPECIFIC GRAVITY:

Use a hydrometer to check the Battery specific gravity.

Checking Gravity:

- Hydrometer
- Battery

NOTICE

Do not take readings immediately after adding distilled water. If water and acid are not thoroughly mixed, the reading may not be accurate.

Check the hydrometer against this chart

SPECIFIC GRAVITY @ 80°F (27°C)	BATTERY CONDITION
1.265	100% Charged
1.225	75% Charged
1.190	50% Charged
1.155	25% Charged
1.120	Discharged

NOTICE

If the readings are taken when the battery electrolyte is any temperature other than 80°F(27°C), the reading must be temperature corrected. To find the corrected specific gravity reading when the temperature of the battery electrolyte is other than 80°F(27°C): add (+) to the specific gravity reading 0.004 (4 points), for each 10°F(6°C) above 80°F(27°C). Subtract (-) from the specific reading 0.004 (4 points), for each 10°F(6°C) below 80°F(27°C).

PM RECORDS

CUSTOMER INFORMATION

CUSTOMER		EMAIL	
ADDRESS			PHONE
CITY	STATE	ZIP	CONTACT

MACHINE INFORMATION

MODEL #:	SERIAL #:
WORK ORDER#:	HOUR METER (Key):
CHASSIS HOUR METER:	HOUR METER (Traction):
RECHARGE NUMBER:	HOUR METER (Scrub):
ISOLATOR HOUR METER:	RE-CHARGE COUNTER:

NOTE: Isolators need to be replaced on Scrubber Machines at 250 Hours or Annually

BATTERY CONDITION	CELL 1	CELL 2	CELL 3	CELL 4	CELL 5	CELL 6
BATTERY 1 HYDROMETER						
BATTERY 1 WATER CONDITION						
BATTERY 2 HYDROMETER						
BATTERY 2 WATER CONDITION						
BATTERY 3 HYDROMETER						
BATTERY 3 WATER CONDITION						
BATTERY 4 HYDROMETER						
BATTERY 4 WATER CONDITION						
BATTERY 5 HYDROMETER						
BATTERY 5 WATER CONDITION						
BATTERY 6 HYDROMETER						
BATTERY 6 WATER CONDITION						

CLEAN BATTERY TOPS. CHECK BATTERY CABLE AND TERMINAL CONDITION.

NOTES:

PAD/BRUSH CONDITION

SCRUB BRUSH FIBER LENGTH	ROTATED BRUSHES		
BROOM DRIVER SOCKETS (4)	GOOD	WORN	NEEDS REPLACEMENT
DRIVER IDLER HUBS	GOOD	WORN	NEEDS REPLACEMENT
SIDE BROOM CONDITION	GOOD	WORN	NEEDS REPLACEMENT ROTATED SIDE TO SIDE
DISK PAD DRIVER	GOOD	WORN	NEEDS REPLACEMENT
EDGE PAD GRIP FACE	GOOD	WORN	NEEDS REPLACEMENT

CHECK OPERATION AND CONDITION OF:	IN SPEC	REPAIR	PROBLEM
STEERING WHEEL TILT MECHANISM			
MAIN POWER SWITCH OR KEY SWITCH			
LCD DISPLAY			
PAGE BUTTON			
BRUSH PRESSURE TOGGLE			
MANAGERS LOCK OUT			
REVERSE SWITCH			
BRUSH SWITCH			
SOLUTION +/- SWITCH			
SOLUTION SOLENOID			
LOW SOLUTION LIGHT			
BRUSH DECK LIFT SYSTEM			
BRUSH MOTORS			

VACUUM SWITCH			
VACUUM MOTOR PERFORMANCE			
OFF-BOARD VAC SWITCH			
SQUEEGEE LIFT SYSTEM			
SQUEEGEE ADJUSTMENT PITCH AND HEIGHT			
SQUEEGEE BLADES			
DRAIN HOSE AND PLUG			
SIDE BROOM OPERATION			
SPRAY JET PUMP, HOSE & NOZZLE			
BATTERY CHARGER CONNECTION & FUNCTION			
PITCH OF SCRUBDECK (MUST BE LEVEL)			
PITCH OF EDGE DECK (MUST BE LEVEL)			
FOOTPEDAL			
PARKING BRAKE			
BACK UP ALARM (REVERSE ONLY - OPTIONAL)			

CLEAN AND / OR LUBRICATE	IN SPEC	REPAIR	PROBLEM
SOLUTION TANK CONDITION			
SQUEEGEE PIVOT POINTS & KNOBS			
SOLUTION FILTER CLEANING			
SCRUB DECK LINKAGE			
STEERING CHAIN			

VISUALLY INSPECT	IN SPEC	REPAIR	PROBLEM
SOLUTION TANK CONDITION			
RECOVERY TANK & GASKET CONDITION			
DRAIN SAVER			
VACUUM FLOATS & SCREENS			
VACUUM HOSES			
SOLUTION HOSES			
BLADE RETAINERS & HARDWARE			
SQUEEGEE WHEELS			
BRUSH SKIRTS			
REAR WHEELS CONDITION			
DRIVE WHEEL CONDITION			

COMMENTS

SERVICING DISTRIBUTOR _____

TECHNICIAN'S NAME _____ DATE _____ SIGNATURE _____

CUSTOMER'S NAME _____ DATE _____ SIGNATURE _____

TROUBLE-SHOOTING

PROBLEM	CAUSE	SOLUTION
NO POWER - NOTHING OPERATES	FAULTY POWER SWITCH BATTERIES NEED CHARGING FAULTY BATTERIES LOOSE BATTERY CABLE MAIN CIRCUIT BREAKER TRIPPED	CONTACT LOCAL SERVICING DEALER SEE CHARGING BATTERIES REPLACE BATTERY TIGHTEN LOOSE CABLE WAIT 5 MINUTES FOR AUTO RESET DETERMINE CAUSE AND CORRECT
SCRUBMOTOR DOES NOT OPERATE	FOOT PEDAL IS NOT DEPRESSED CIRCUIT BREAKER TRIPPED FAULTY SCRUBDECK MOTOR OR WIRE	DEPRESS FOOT PEDAL RESET AND REDUCE PRESSURE CONTACT LOCAL SERVICING DEALER
VACUUM MOTOR DOES NOT OPERATE	FAULTY VACUUM SWITCH CIRCUIT BREAKER TRIPPED FAULTY VACUUM MOTOR CARBON BRUSHES WORN	REPLACE SWITCH RESET AND CHECK HOSE DETERMINE CAUSE AND CORRECT CONTACT LOCAL SERVICING DEALER CONTACT LOCAL SERVICING DEALER
INSUFFICIENT SOLUTION FLOW	SOLUTION TANK LOW FLOW LEVER TURNED DOWN SOLUTION FILTER CLOGGED SOLUTION LINE CLOGGED SOLUTION VALVE CLOGGED	REFILL SOLUTION TANK TURN LEVER MORE OPEN REMOVE COVER AND CLEAN REMOVE AND BLOW OUT WITH COMPRESSED AIR REMOVE COVER AND CLEAN
NO SOLUTION FLOW	NO SOLUTION IN TANK SOLUTION SWITCH IS OFF SOLUTION SCREEN IS CLOGGED FAULTY SOLUTION SOLENOID FAULTY SOLUTION SWITCH	FILL SOLUTION TANK TURN SOLUTION SWITCH ON REMOVE AND CLEAN SCREEN CONTACT LOCAL SERVICING DEALER CONTACT LOCAL SERVICING DEALER
POOR WATER RECOVERY	RECOVERY TANK IS FULL BALL/SCREEN IS CLOGGED VACUUM HOSE IS CLOGGED SQUEEGEE IS CLOGGED SQUEEGEE BLADE IS WORN FAULTY VACUUM HOSE VACUUM MOTOR GASKET TORN TANK GASKET FAULTY DRAIN PLUG LOOSE VACUUM MOTOR FAULTY BATTERY CHARGE LOW	EMPTY RECOVERY TANK REMOVE SCREEN AND CLEAN REMOVE DEBRIS REMOVE DEBRIS ROTATE OR REPLACE BLADES CONTACT LOCAL SERVICING DEALER CONTACT LOCAL SERVICING DEALER CONTACT LOCAL SERVICING DEALER TIGHTEN PLUG CONTACT LOCAL SERVICING DEALER CHARGE BATTERIES OVERNIGHT

PROBLEM	CAUSE	SOLUTION
POOR WATER RECOVERY ON TURNS	WIPERS WORN	REPLACE WIPER MATERIAL
	WIPERS CHATTER	TIGHTEN PIVOT POINTS
	SQUEEGEE SWING IS BINDING	CONTACT LOCAL SERVICING DEALER
	INCORRECT SQUEEGEE SIZE	CONTACT LOCAL SERVICING DEALER
TIRES NOISY	BEARING DRY	GREASE BEARINGS
	FAULTY HUBS	CONTACT LOCAL SERVICING DEALER
POOR TRACTION	EXCESSIVE BRUSH PRESSURE	REDUCE PRESSURE WITH SWITCH
	WORN DRIVE TIRE	REPLACE TIRES
	HEAVY SOAP CONCENTRATION	CONTACT LOCAL SERVICING DEALER
PARKING BRAKE DOESN'T WORK	NOT ON A LEVEL FLOOR	MOVE TO LEVEL SURFACE TO PARK MACHINE
	OVERRIDE LEVER IN OFF POSITION	RESET LEVER INTO CORRECT POSITION
	PARKING BRAKE MALFUNCTION	CONTACT LOCAL SERVICING DEALER
SHORT RUN TIME	BATTERIES RUN DOWN	CHARGE BATTERIES TWICE
	BATTERIES STILL DOWN	CONTACT LOCAL SERVICING DEALER
	BATTERIES LOW ON WATER	FILL WITH DISTILLED WATER TO $\frac{3}{4}$ " ABOVE THE LEAD PLATES
	BATTERIES OVER CYCLED	CONTACT LOCAL SERVICING DEALER

TROUBLE-SHOOTING CENTRAL COMMAND

NOTE: This machine is operated by a sophisticated electronic “controller” that has many fail safes within it. It self-analyzes problems and flashes a four-digit alpha-numeric code of what is wrong in the LCD window.

Most of these codes require a technician attention. You should not attempt repairs you are unfamiliar with, especially if you are not authorized to work on this equipment.

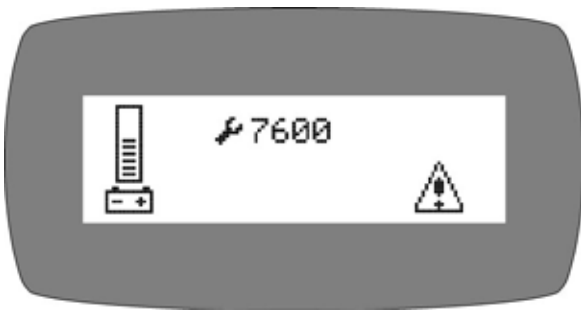

1. 7601 and 7602 ERROR: Scrubdeck current over load. This can occur when driving over a bump in the floor. To restart, turn *OFF* the Key and turn it on again. To avoid this error, either slow down on bumpy parts of the floor, or reduce down pressure on the Scrubdeck.

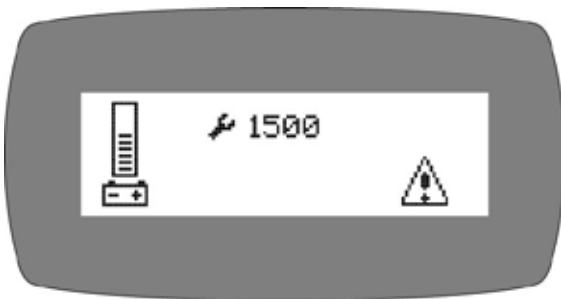

2. 1500 ERROR: There is an open in the parking brake circuit. Check the parking brake wiring and the parking brake coil to find the open circuit.

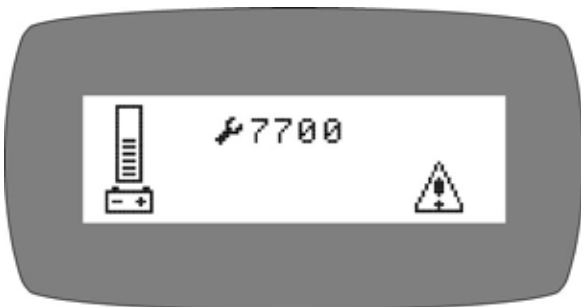

3. 770, 7701, 7702, and 7703 ERROR: The vacuum motor has exceeded their authorized power limits. Turn *OFF* Key and turn *ON* again to clear.



4. BOOST ON: Allows front wheel drive to draw more power when needed to climb ramps for 30 seconds.

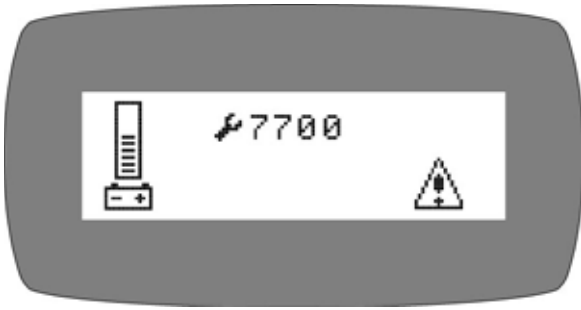

5. **7700:** Vacuum Motor circuit is open.

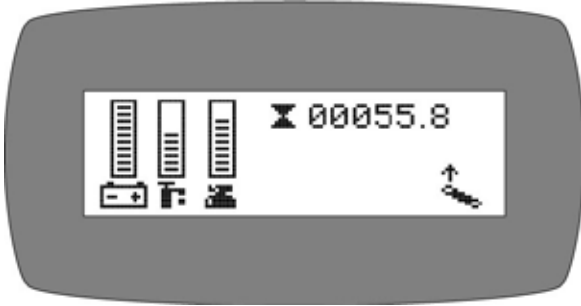

6. **Throttle ERROR:** You pressed the foot pedal before turning on the key. Turn *OFF* the key and try again, leaving foot off of the pedal.

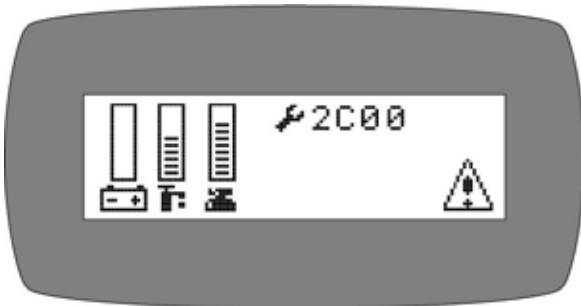

7. **2C00 and 2C01 ERROR:** Low voltage warning. Voltage has dropped down below the minimum required to operate the machine. If you wait a few minutes, the Batteries may come up in voltage, allowing you to drive very slowly to the recharge station. If not, you will have to release the parking brake (on the front wheel, pull lever toward the front of the machine to release) and push the machine to recharging station. You must disconnect the traction motor! (+ cable first)

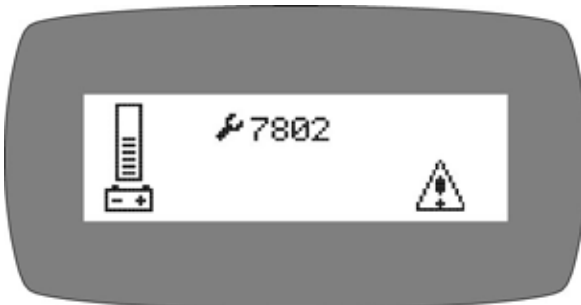

8. **7802 ERROR:** The traction motor pulled excessive current perhaps running a ramp for more than the 60 seconds allowing for this. Turn *OFF* the Key, turn on again, and continue. You should not use this machine to climb ramps so steep and so long that this code comes up repeatedly, or you could overheat the traction motor.

9. **All other ERROR codes:** Turn *OFF* the Key, and disconnect the positive battery cable from the Batteries for more than one minute (*the time is needed to drain the controller on-board capacitor*). Reconnect cables, being sure that it is tight. ***Too loose and you will burn Battery. If you over tighten the cables you can damage the Battery lead terminal. Try again.***

10. If the problems cannot be solved by any of this solution, call your local dealer service department.

MACHINE SPECS

BODY CONSTRUCTION/DIMENSIONS

Tank Material:
Chassis Construction:
Rear Wheels:
Size (L x W x H):
Weight (without Batteries):
Weight (with standard Batteries):

GTX

Poly ($\frac{3}{8}$ ") (0.9525 cm)
 $\frac{3}{16}$ " Steel (.2 cm)
(2x) 12" x 5" [(2x) 30.5 x 12.7 cm]
54" x 26" x 55" (137 x 66 x 139 cm)
780 lb
1,222 lb

SCRUBDECK SYSTEM

Disk Brush Size:

Disk Scrubdeck Motor:
Optional Scrubdeck Motor:
Cylindrical Brush Size:

Cylindrical Brush Speed:
Cylindrical Scrubdeck Motor:
HD Cylindrical Scrubdeck Motor:
NOTE: HD Option is Standard on 30"/34" Cylindrical Decks
EDGE Pad Size:

EDGE Scrubdeck Motor:
Optional EDGE Scrubdeck Motor:
Scrubdeck Down Pressure:

26-D: (2x) 13" (56 cm)
30-D: (2x) 15" (38 cm)
34-D: (2x) 17" (43 cm)
(1x) .75 hp (559 watts) / 300 rpm
(1x) 1 hp (746 watts) / 350 rpm
24-C: (2x) 22" (55.8 cm)
27-C: (2x) 25" (63.5 cm)
30-C: (2x) 28" (71 cm)
34-C: (2x) 32" (81 cm)
750 rpm
(2x) .75 hp (559 watts) / 350 rpm
(2x) 1.0 hp (746 watts) / 350 rpm

28-E: (1x) 28"x14" (71 x 35 cm)
32-E: (1x) 32"x14" (81 x 35 cm)
(1x) 1.0 hp (746 watts) / 2500 rpm
(1x) 1.2 hp (746 watts) / 2900 rpm
0-250 lb (0-113 kg)

SOLUTION SYSTEM

Solution Tank Capacity:
Solution Flow Rate:
Solution Filter:

35 gal (132 liters)
0 - 0.75 gpm (0 - 4 lpm)
Stainless / In-line

RECOVERY SYSTEM

Recovery Tank Capacity:
Vacuum Power:
Drain Hose:
Vacuum Specs (Lift/Airflow):
Demisting Chamber:
Drain Saver:

35 gal (132 liters)
1.0 hp or 2.0 hp (745 watts)
2" Diameter (5 cm)
68" / 70 cfm (172 cm / 21cm)
3 gal (5 liters)
60 in³ (152 cm³)

BATTERY SYSTEM

System Voltage:
Standard Battery Ah Rating:
Optional Battery Ah Rating:
Battery Run Time (Standard):
Charger (Automatic):

36 Volts
(6x) 245 Ah
Up to (6x) 360 Ah
Up to 7 Hrs
25 Amp

DRIVE SYSTEM

Standard Drive:
Speed Control:

1.0 hp (745 watts), Sealed
Variable 0-320 ft/min

PRODUCTIVITY

Scrubbing Width & Rate/Hour:

24" / 26,400 sq.ft/hr
26" / 28,600 sq.ft/hr
27" / 29,700 sq.ft/hr
30" / 30,000 sq.ft/hr
34" / 37,400 sq.ft/hr

COMMON WEAR PARTS

ROUND DISK BRUSHES:

BRUSHES	MODEL 26" DISK	MODEL 30" DISK	MODEL 34" DISK
Super Grit	13-421SS	15-421SS	17-421SS
Tough Grit	13-421S	15-421S	17-421S
Midi Grit	13-421C	15-421C	17-421C
Light Grit	13-421PS	15-421PS	17-421PS
Poly (.028)	13-421P	15-421P	17-421P
Nylon (.016)	13-421N	15-421N	17-421N
Tampico	13-421T	15-421T	17-421T
Pad Driver	13-421D	15-421D	17-421D
Diamond Driver	13-421DD	15-421DD	17-421DD

ROUND DISK PADS:

NOTICE

The ## in Disk Column Denotes Desk Pad Size: 13", 15" or 17"

DISK PADS	DISK	LEVEL	COLOR
Super Black	##-422BB	Very High	Black
Black	##-422B	High	Black
Brown	##-422BR	High	Brown
Green	##-422G	Medium	Green
Blue	##-422BL	Moderate	Blue
Red	##-422R	Moderate	Red
White	##-422W	Light	White

EDGE PADS AND SCREENS:

DESCRIPTION	28"×14"	32"×14"
	SCRUBDECK	SCRUBDECK
White Pad	EDGE-4054	EDGE-5005
Red Pad	EDGE-4053	EDGE-5004
Blue Pad	EDGE-4052	EDGE-5009
Green Pad	EDGE-4051	EDGE-5002
Black Pad	EDGE-4050	EDGE-5001
White Driver Pad	EDGE-4058	N / A
60 Grit Sand Screen	EDGE-4059	N / A
80 Grit Sand Screen	EDGE-4060	N / A
100 Grit Sand Screen	EDGE-4061	EDGE-5028
120 Grit Sand Screen	EDGE-4062	EDGE-5029
150 Grit Sand Screen	EDGE-4063	N / A
Tile/Grout Renovator Pad	EDGE-4048	N / A
Dominator HD Strip Pad	EDGE-4055	N / A
Maroon ECO Prep Pad	EDGE-4056	EDGE-5007

Remover Burnishing Pad	EDGE-4057	EDGE-5008
Porko Burnishing Pad	EDGE-4047	N / A
Velcro Pad	300-4024	N / A

NEW STYLE CYLINDRICAL BRUSHES:

For Machine Serial #50000 & Greater

BRUSHES	MODEL 24" CYLINDRICAL	MODEL 27" CYLINDRICAL	MODEL 30" CYLINDRICAL	MODEL 34" CYLINDRICAL
Super Grit	N / A	N / A	N / A	N / A
Tough Grit	225-821S	255-821S	285-821S	325-821S
Midi Grit	225-821C	255-821C	285-821C	325-821C
Light Grit	225-821PS	255-821PS	285-821PS	325-821PS
Poly (.028)	N / A	N / A	N / A	N / A
Nylon (.016)	225-821N	255-821N	285-821N	325-821N

OLD STYLE CYLINDRICAL BRUSHES:

For Machines Prior To Serial #50000

BRUSHES	MODEL 24" CYLINDRICAL	MODEL 27" CYLINDRICAL	MODEL 30" CYLINDRICAL	MODEL 34" CYLINDRICAL
Super Grit	N / A	N / A	N / A	N / A
Tough Grit	22-521S	25-521S	28-521S	32-521S
Midi Grit	22-521C	25-521C	28-521C	32-521C
Light Grit	22-521PS	25-521PS	28-521PS	32-521PS
Poly (.028)	N / A	N / A	N / A	N / A
Nylon (.016)	22-521N	25-521N	28-521N	32-521N

SQUEEGEE BLADE KITS & COMPLETE SQUEEGEE ASSEMBLIES:

SQUEEGEE SIZE	24" CYL DECKS	26" DISK DECKS	27" CYL DECKS	30" DISK DECKS	30" CYL DECKS	34" DISK & CYL DECKS	GUM RUB- BER BLADE KIT	LINATEX BLADE KIT	COMPLETE SQUEEGEE ASSEMBLIES
32" Squeegee	Standard	Standard	Optional	Optional	Optional	N / A	22-770G	22-770L	23-7180
35" Squeegee	Optional	Optional	Standard	Standard	Optional	N / A	25-770G	25-770L	25-7180
38" Squeegee	Optional	Optional	Optional	Optional	Standard	Standard	28-770G	28-770L	28-7180
45" Squeegee	N / A	N / A	N / A	N / A	N / A	Optional	290-770G	290-770L	290-7180

NOTICE

Squeegee blade kits include (1) Rear Blade, (1) Front Blade, and (2) Backup Wheels with hardware.

NOTICE

Squeegee Assemblies (complete) listed above all come with Linatex blades.

NOTICE

Size is stamped into the top of the painted steel squeegee body on all squeegee's.

NOTICE

The 32" squeegee is designed for narrow aisles and may not have the same water control around tight turns as the large squeegees.

SOAP CHOICES



Industrial • Commercial • Environmentally Safe

TRADITIONAL DRUMS / TOTES



DEMO / RENTAL QUARTS



WALL-MOUNTED SUPERCON



ONBOARD AUTO DISPENSING



Onboard
Availability

FORMULAS

SUDS
Approved



707 Citrus Green An environmentally cleaner that works! It is a solvent free degreaser that works on oil, carbon, even rubber marks. Incorporates the latest technology in "Green Cleaning".

SUDS
Approved



733 Low pH Safe on most surfaces not harmed by water alone. Low scale formula to prevent alkali buildup in cleaning equipment, while offer detergent to emulsify oil.

SUDS
Approved



755 High Power Ideal solvent fortified degreaser. This butyl based detergent is penetrating, fast acting, and deep cleaning with built-in corrosion inhibitors. It is our most effective degreaser.

SUDS
Approved



757 Gloss A high gloss detergent designed to dry to a bright shine. It is ideal for use on finished surfaces, tile, epoxy, or enamel. The special formula removes salt residue, scuff marks and dirt, while leaving no residue behind. The result is a clean, non-slip surface, ready for immediate use.

SUDS
Approved



797 HD The Heavy Duty concentrate is a Super alkaline detergent, formulated for heavy soil, grease, and thick buildup. Popular in machine shops, auto and truck repair, and other facilities with oil, hydraulic fluids and cutting oils.

***Below Sold in bulk concentrate only. Not available as a SuperCon, PowerDose or SUDS product.*

727 Pretreat** Designed to quickly remove tire marks, oil stains and buildup that has accumulated. This pretreat uses the powerful cleaning of natural citrus extract and is intended to be used directly on the floor at 100% concentrate.

744 Tough Stuff** Ideal for applications with Hard Water problems. It is safe to use in pressure washers and automatic scrubbers. The formulation enhances soil suspension, digests oil and grease, while supporting extra water conditioner.

PowerCat
P.O. Box 503
Racine, WI 53404-0503
Phone: 414-745-9337
Fax: 262-632-1630
www.powercatsolutions.com

Distributed by:

PowerCat, LLC, 2008.

STANDARD WARRANTY POLICY

RPS Corporation warrants its machines, parts and accessories to be free of manufacturer's defects for the periods specified below. Warranty will be granted at the sole discretion of RPS Corporation and is subject to final claim and parts review by R.P.S. Corporation and its vendors. This policy is effective January 1, 2013 and is subject to change on production units at a future date.

COVERAGE, EXCLUSIONS AND LIMITATIONS:

Coverage: All Models Except Floor Machines: 1 Year Parts / 6 Months Labor / No Travel
ZerO3 Wall Mount Units: 6 Months Parts

Parts: 36 months / 1,500 hours on "Power On" hour meter

Labor: 12 months

Travel: 3 months (150 mile maximum)

Poly Tanks: 7 Years (Water must not exceed 135°F/57°C) / 3,000 Hours

OEM Parts: 90 Day New Part Warranty

Validity: Fully completed Machine Delivery Form (online or fax) is on record at RPS and machine is serviced by Factory Authorized Personnel.

Limitation: Warranty will begin on date of machine installation to end-user or 6 months after shipment from RPS Corp. to the distributor if unsold at that time.

This warranty includes all parts on the machine except normal wear parts. Some of these exceptions are:

- EDGE / ORBITZ isolators (250 hours on average)
- Squeegee Blades, Wiper Blades, Skirts and Curtains.
- Caster Wheels, Squeegee Wheels and Bumpers.
- Lights (Strobe, Headlights, or Bulbs).
- Chains and Belts.
- Filters, Screens, and Vacuum Bags.
- Motor Brushes and commutator wear.
- Brooms, Brushes, Pads and Pad Retainers.
- Hoses and Tubing.
- Drive Tires, Pneumatic Wheels and Tubes.
- Rubber Floor Seals and Gaskets.
- Vacuum motors with evidence of moisture or debris intrusion or > 400 hours.
- The Batteries (see below).
- **NOT COVERED:** Routine maintenance, adjustments or parts damaged from abuse, neglect, improper use of the machine, or lack of scheduled "daily, weekly, monthly" maintenance in accordance with our published PM Sheets.

POLY TANKS: 7 Years Coverage against leakage due to manufacturer's defect in materials or workmanship. Tank warranty void if water used exceeds 135°F/57°C

NOTE: Freight coverage for 3 Years under the parts section of warranty.

BATTERIES: Warranted through battery manufacturer for **One (1) Year** (pro-rated) from the date of delivery. The battery manufacturer approves or denies the warranty coverage after analysis. We rely on solely on their review.

NOTE NOT COVERED: Damage from lack of water, failure to use OEM charger, or non-distilled water. Battery terminals – Battery terminals and cable connections are covered for 30 days from the shipment of the machine. (Battery terminals tightness should be inspected every 30 days.)

MACHINE INSTALL / WARRANTY REGISTRATION

Installing Dealer: _____ **Installed By:** _____

Location: (City, State): _____ **Install Date:** _____

End-User Company Name: _____ **End-User Contact:** _____

Address: _____ **City/State:** _____ **Zip:** _____

Phone: _____ **Fax:** _____ **Email:** _____

Model: _____ **Serial #:** _____ **Hour Meter:** _____

BUYER'S REPRESENTATIVE HAS RECEIVED INSTRUCTION IN PROPER OPERATION OF THE FOLLOWING CONTROLS AND FEATURES:

SCRUBBERS:

- Filling solution tank, Solution tank sight tube, Solution drain hose or valve for flushing and freezing conditions
- Adjusting controls & operation, Double scrubbing, Squeegee lift delay, High Recovery RED Light, vacuum switch (horn honking) and vacuum timer
- Recovery tank draining & cleaning in APPROVED locations only, Common Squeegee hose clog points, vacuum screen removal and cleaning, drain saver basket emptied
- Shroud and pad/brush removal and installation
- Side Wiper and Curtain adjustment and maintenance for water control
- Solution valve and filter operation (removal and cleaning)
- LCD display operation, 4 hour meters (key switch, brush, traction drive, vacuum)
- Tank tilt back feature, only when both tanks are fully drained
- Squeegee hose removal and checking for clogs

BURNISHERS

- Train and have customer demonstrate proper removal and replacement of burnishing pad
- Pad pressure gauge and proper operating range to avoid tripping the circuit breaker

SWEEPERS

- Demonstrate proper removal and replacement of main broom and side brooms
- Method for cleaning the dust filter, emptying out the debris hopper and correct installation
- Correct operation of the main broom and side broom levers, and understands to park with brushes in UP position
- Trained on the "Wet-Sweep" bypass door and not to operate through standing water

EDGE MACHINES

- EDGE scrubbers must have their isolators & deck hour meter replaced every 250 hours of use
- Customer understands the Grip Face is not warranted against damage from improper use or direct contact with the floor

ALL MACHINES

- Checking for proper battery electrolyte level, electrolyte condition monthly, and check that battery terminals are properly torqued to 10ft/lbs
- Parking Brake works and Park Brake Override functions if installed / Always park on a solid and level surface, NEVER on a movable or inclined surface
- Charging operation and customer understands batteries have limited "cycles" and recharging = 1 cycle
- Seat and steering wheel adjustment
- Customer has read and understands the list of WARNINGS/CAUTIONS in the Operator manual
- Battery and Machine Maintenance Guide posters hung up and reviewed
- Manufacturer's website is a good source of information (Videos, PM Sheets) and sign up for quarterly newsletters
- Operators and Parts manuals were delivered, reviewed, understood, and confirmation preventive maintenance is done every 100 hours of use and recorded on PM Sheets provided online or in manuals

Installed By (print) _____ **Signature** _____

Buyers Representative (print) _____ **Signature** _____

Buyer agrees to pay for any repairs, adjustments, or secondary training that manufacturer determines is excluded from the warranty.

Complete and Fax form to 1-866-632-6961 or Online at www.rpsccorporation.com



1711 South Street
Racine, WI 53404
www.rpsccorporation.com
www.factorycat.com
www.tomcatequip.com
Tel. US: 800-634-4060
Tel. Int: (011) 262-681-3583
Fax: 866-901-3335