

## Operating Instructions (EN)

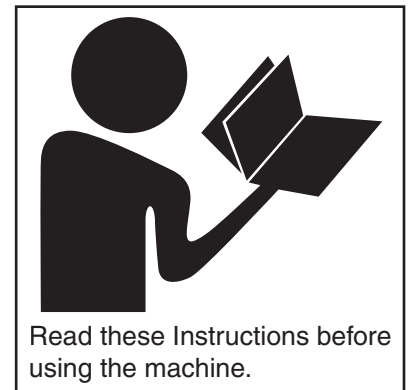

Read these Instructions before using the machine.

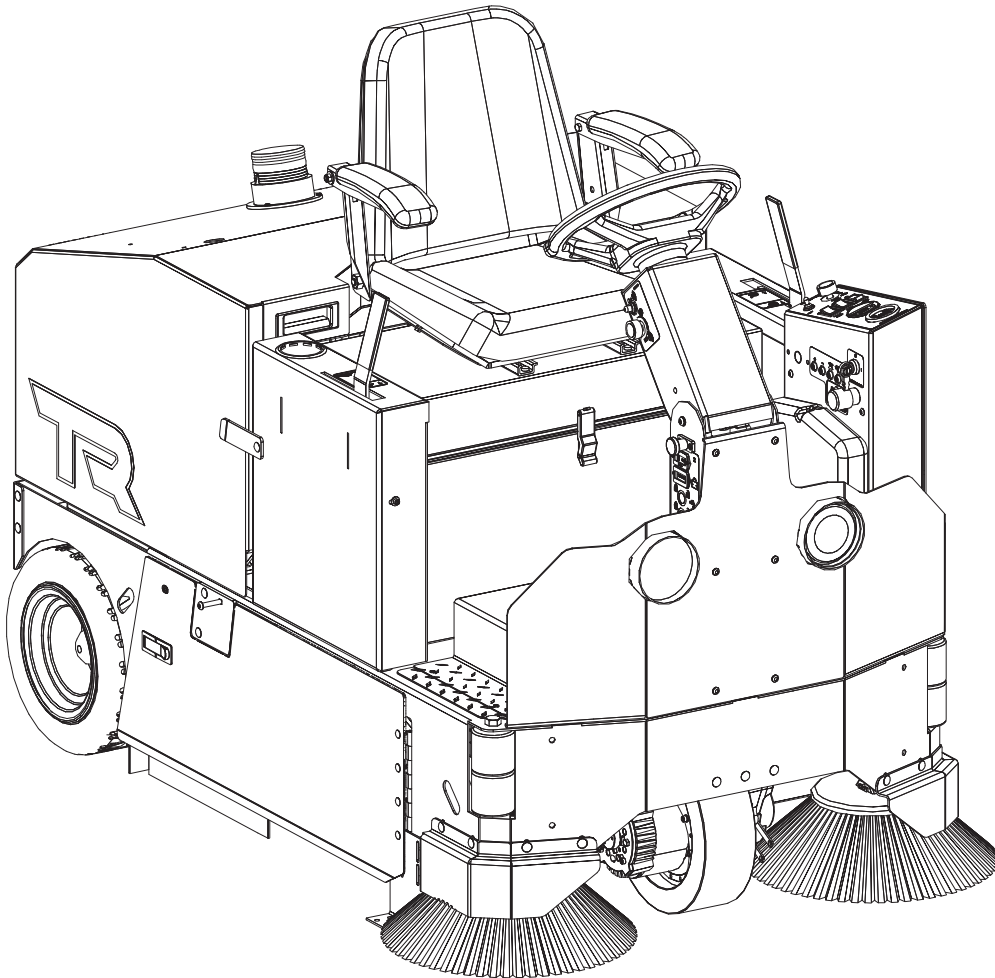

Read these Safety Messages before using the machine.

## INTRODUCTION

This manual is furnished with each new machine. This manual will allow the Operator to get the best performance out of your RPS manufactured Scrubber-Drier, Sweeper, Burnisher, or Orbital Scrubber. Read this manual thoroughly before operating or servicing the machine.

This machine will provide excellent performance, but the best results will be obtained at the most minimum costs if:

- The machine is regularly maintained - per the machine Preventative Maintenance instructions provided.
- The machine is operated with reasonable care and caution.
- The machine is maintained with manufacturer supplied parts.

## ABOUT THIS MANUAL

**TABLE OF CONTENTS:** Tells you where to look in the manual.

**SAFETY MESSAGES:** Section contains important information regarding hazard or unsafe practices of the machine. Levels of hazards are identified that could result in product or personal injury, or severe injury resulting in death.

**OPERATION CONTROLS / MACHINE COMPONENTS:** Shows you the different machine controls and features.

**MACHINE SETUP:** Tells you how to setup machine from un-crating to installing squeegee and brushes.

**MACHINE OPERATION:** Section is to familiarize the operator with the operation and function of the machine.

**BATTERY CHARGING:** Shows you how to charge the batteries (on-board and off board charging).

**MAINTENANCE:** This section contains preventative maintenance to keep the machine and it's components in good working condition. They are listed in this general order:

- Batteries
- Brooms
- Filters
- Service Schedule
- Machine Trouble Shooting

**TROUBLE SHOOTING:** A list of common problems that may occur.

**MACHINE SPECS:** Tells you Machine Specifications for the various parts of the machine.

**MACHINE INSTALL FORM:** Should be filled out upon machine installation and faxed to 1-866-632-6961 or online at [www.rpscoperation.com](http://www.rpscoperation.com).

**WARRANTY POLICY:** Tells you coverage, exclusions and limitations to warranty.

**NOTE:** The serial number of your machine is located on the lower half of the Steering Pedestal of the machine.

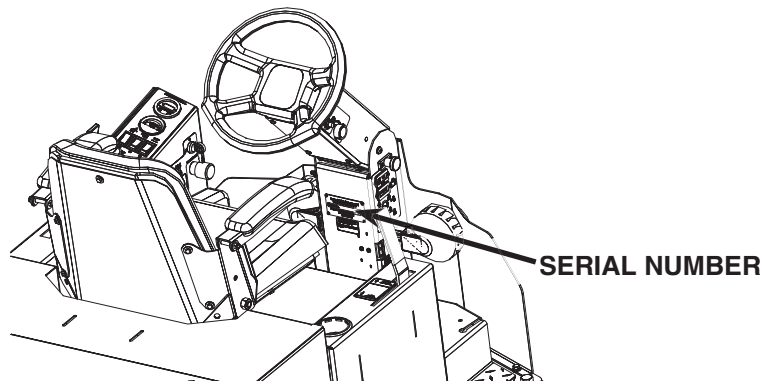

AS OUR POLICY IS ONE OF CONSTANT IMPROVEMENT - ALL INFORMATION AND SPECIFICATIONS ARE SUBJECT TO CHANGE WITHOUT NOTICE.

## TABLE OF CONTENTS

<p><b>Introduction</b>.....2</p> <p><b>About This Manual</b>.....2</p> <p><b>Table of Contents</b>.....3</p> <p><b>Safety Messages</b>.....4</p> <p><b>Safety Label Locations</b>.....6</p> <p><b>Operation Controls</b>.....7</p> <p><b>Operation Controls</b>.....8</p> <p><b>Operation Controls</b>.....9</p> <p><b>Machine Components</b>.....10</p> <p><b>Machine Components</b>.....11</p> <p><b>Machine Setup</b>.....12</p> <p style="padding-left: 20px;">Un-Crating Machine:.....12</p> <p style="padding-left: 20px;">Connecting Batteries:.....12</p> <p style="padding-left: 20px;">Installing Main Broom:.....12</p> <p style="padding-left: 20px;">Installing Side Brooms:.....13</p> <p style="padding-left: 20px;">Adjusting Side Brooms:.....13</p> <p><b>Machine Setup</b>.....13</p> <p style="padding-left: 20px;">Pre-Cleaning Checklist:.....13</p> <p style="padding-left: 20px;">Operating Hints:.....13</p> <p style="padding-left: 20px;">Sweeping:.....14</p> <p style="padding-left: 20px;">WET Sweeping:.....14</p> <p style="padding-left: 20px;">Cleaning Filter:.....15</p> <p style="padding-left: 20px;">Changing Filter:.....15</p> <p style="padding-left: 20px;">Empty Hopper:.....15</p> <p><b>On-Board Charger</b>.....16</p> <p style="padding-left: 20px;">On-Board Battery Charging (Optional):.....16</p>	<p><b>Description of LED:</b>.....16</p> <p><b>Battery Charging</b>.....17</p> <p style="padding-left: 20px;">External Battery Charging:.....17</p> <p><b>Battery Maintenance Guide</b>.....18</p> <p style="padding-left: 20px;">Safety:.....18</p> <p style="padding-left: 20px;">Inspection and Cleaning:.....18</p> <p style="padding-left: 20px;">Storage:.....18</p> <p style="padding-left: 20px;">Watering:.....18</p> <p><b>Maintenance</b>.....19</p> <p style="padding-left: 20px;">Daily Maintenance:.....19</p> <p style="padding-left: 20px;">Weekly Maintenance:.....19</p> <p style="padding-left: 20px;">Monthly maintenance:.....19</p> <p style="padding-left: 20px;">Yearly Maintenance:.....19</p> <p style="padding-left: 20px;">Storing Machine:.....19</p> <p style="padding-left: 20px;">Checking Battery Specific Gravity:.....19</p> <p><b>PM Records</b>.....20</p> <p><b>Trouble-shooting</b>.....22</p> <p><b>Machine Specs</b>.....23</p> <p><b>Common Wear Parts</b>.....24</p> <p style="padding-left: 20px;">Cylindrical Brooms:.....24</p> <p style="padding-left: 20px;">Side Brooms:.....24</p> <p style="padding-left: 20px;">Filter Kits:.....24</p> <p><b>Standard Warranty Policy</b>.....25</p> <p><b>Machine Install / Warranty Registration</b>.....26</p>
---	--

## SAFETY MESSAGES

You will see four kinds of safety reminders in this manual:

### **DANGER**

DANGER indicates a hazardous situation which, if not avoided, will result in death or serious injury.

### **WARNING**

WARNING indicates a potentially hazardous situation which, if not avoided, could result in death or serious injury.

### **CAUTION**

CAUTION indicates a potentially hazardous situation which, if not avoided, could result in minor or moderate injury or damage to this machine or nearby objects. CAUTION also can be used to alert against unsafe practices.

### **NOTICE**

NOTICE indicates information considered important, but not hazard-related. This safety message may be related to property damage or warranty warnings.

Your safety, and that of others, is very important. Operating this machine safely is an important responsibility.

### **DO NOT OPERATE THIS MACHINE UNLESS:**

- You are trained and authorized to do so
- You have read and understood this Operator's Manual
- On surfaces with greater than a 2% grade unless this machine is equipped with a functional parking brake.

### **WHEN OPERATING THIS MACHINE:**

- Remove loose objects from the floor that could be projected from the rotating Brushes
- Keep your hands and feet away from the rotating Brushes
- Do not operate this machine where flammable liquids are present
- Use caution when maneuvering

### **BEFORE LEAVING THE MACHINE:**

- Park the machine on a level surface
- Turn the machine off

### **BEFORE SERVICING THE MACHINE:**

- Disconnect the Batteries

### **DANGER**

Explosive hydrogen gas forms when Batteries are charging. An open flame or spark can cause this gas to explode. Serious personal injury or property damage could occur. Only charge the Batteries in this machine in a well ventilated area.

**! WARNING**

The Batteries in this machine produce hazardous voltage which can cause electrical shock, burns and/or electrocution. Always disconnect Batteries before servicing this machine.

**! WARNING**

When climbing or descending ramps, always drive machine forward. To avoid overturning the machine, Do not back down ramps. Do not drive across inclines. Do not turn while ascending or descending ramps. Overturning the machine can cause serious injury or death.

**! WARNING**

Do not park this machine on ramps or slopes. Always park this machine on a level, hard surface. Do not operate this machine outdoors or on uneven surfaces.

**! WARNING**

The Batteries in this machine contain sulfuric acid, which causes burns to skin. If battery acid contacts clothing or skin, rinse the effected area with cold water immediately. If battery acid gets on your face or in your eyes, flush the area immediately with cold water and seek medical attention.

**! WARNING**

To avoid electrical shock, do not operate this machine over electrical floor outlets.

**! WARNING**

Dress safely. Do not wear rings or metal wrist watches when servicing this machine, as they can cause an electrical short circuit which can cause serious burns.

**! CAUTION**

Do not operate this machine if any parts have been damaged or removed.

**! CAUTION**

Always use the automatic battery charger provided by the manufacturer of this machine to charge the Batteries of this machine. It is designed to charge the Batteries at the appropriate rate. If you must use a different charger, disconnect the Batteries before charging to avoid damage to the electronic speed controller.

**! WARNING**

Do not remove, paint over or destroy warning decals. If warning decals become damaged, call 1-262-681-3583 for free replacements.

**! WARNING**

Dress safely. Do not wear a neck tie, scarf, or any loose or dangling clothing while operating this machine. Loose or dangling clothing or neck-wear can tangle in rotating parts, causing serious injury or death.

**! WARNING**

Always turn off this machine before leaving it unattended. Do not allow untrained persons to operate this machine.

**! WARNING**

NO RIDERS. Do not carry passengers on this machine. Do not use this machine as a stepladder or work platform.

**! WARNING**

Understand the dynamic braking system before you operate the machine on ramps. Machine may coast.

**! WARNING**

Before you service a Battery, always wear face protection, protective gloves and protective clothing. Battery acid or battery explosion can cause serious injuries.

**! CAUTION**

To avoid damage to the electronic control components of this machine, Do not store this machine outdoors. Do not pressure wash this machine.

## SAFETY LABEL LOCATIONS

Read and obey all Safety Labels on your TR Floor Sweeper. If you have questions about these labels, ask your supervisor.

These images indicate where on the TR Safety Labels are located. If ever the labels become illegible, worn off, or torn, promptly report it to your supervisor and replace it.

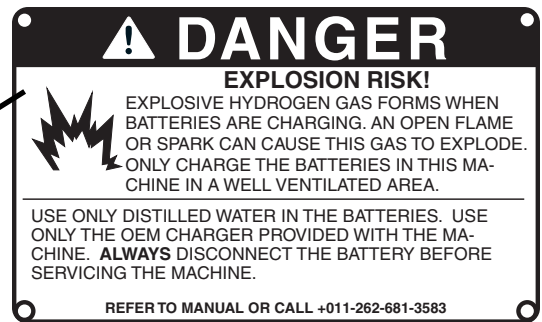
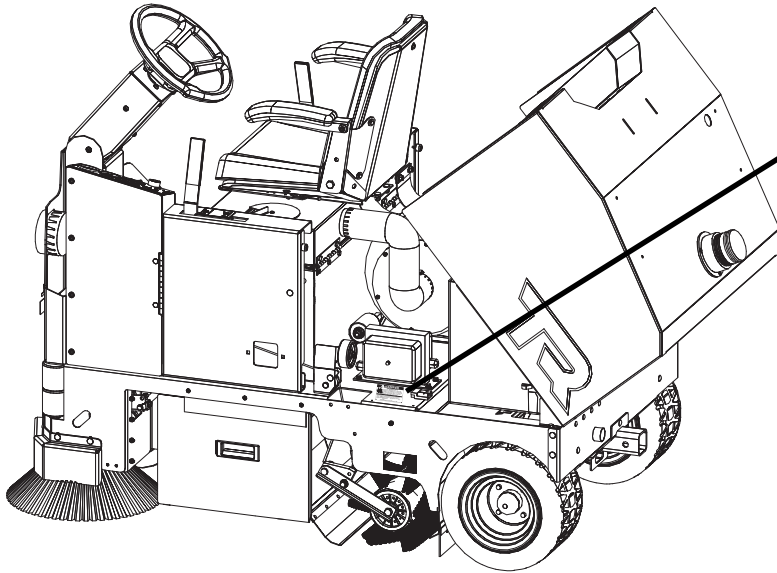

### BATTERY CHARGING LABEL

PART #: 349-7280

## OPERATION CONTROLS

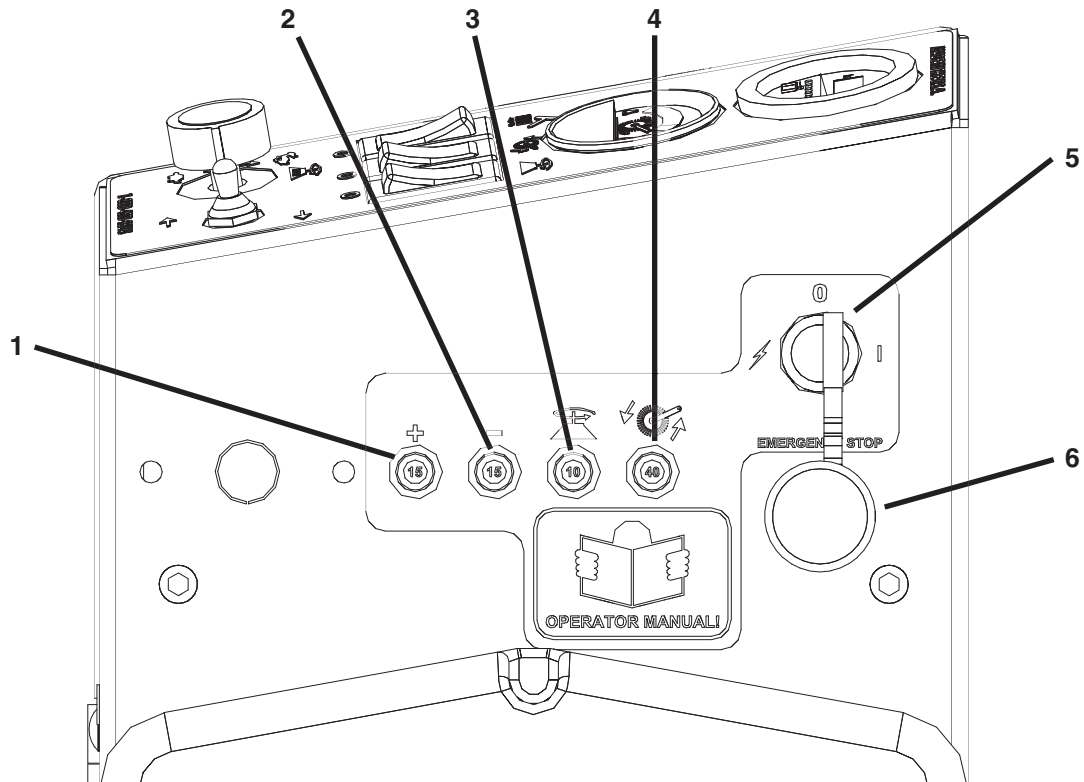

1. **CIRCUIT BREAKER:** 15 AMP resettable circuit breaker
2. **CIRCUIT BREAKER:** 15 AMP resettable circuit breaker
3. **CIRCUIT BREAKER:** 10 AMP Side Broom resettable circuit breaker
4. **CIRCUIT BREAKER:** 40 AMP Main Broom resettable circuit breaker
5. **KEY SWITCH:** Turns power of the machine *ON* and *OFF*
6. **EMERGENCY STOP (OPTIONAL):** 1 button push machine shut down in case of emergency

## OPERATION CONTROLS

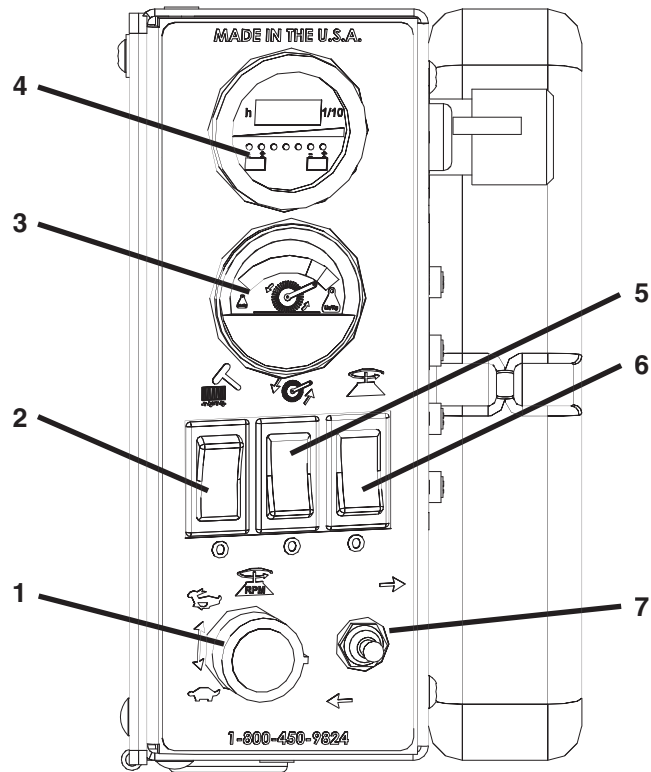

- 1. SIDE BROOM SPEED CONTROL KNOB:** Controls the speed of the Side Brooms - Turn counterclockwise to reduce speed
- 2. FILTER SHAKER SWITCH:** Filter shaker button shakes filter to remove dust or debris particles to deposit into the hopper for removal
- 3. BRUSH AMP GAUGE:** Indicates the amount of amperage that the Main Broom pulling
- 4. BATTERY GAUGE / HOUR METER:** Indicates the amount of battery charge remaining along with total hours used
- 5. MAIN BROOM SWITCH:** Turns the Main Broom *ON* or *OFF*
- 6. SIDE BROOM SWITCH:** Turns the Side Brooms *ON* or *OFF*
- 7. REVERSE SWITCH:** Switch back for reverse machine drive



## OPERATION CONTROLS

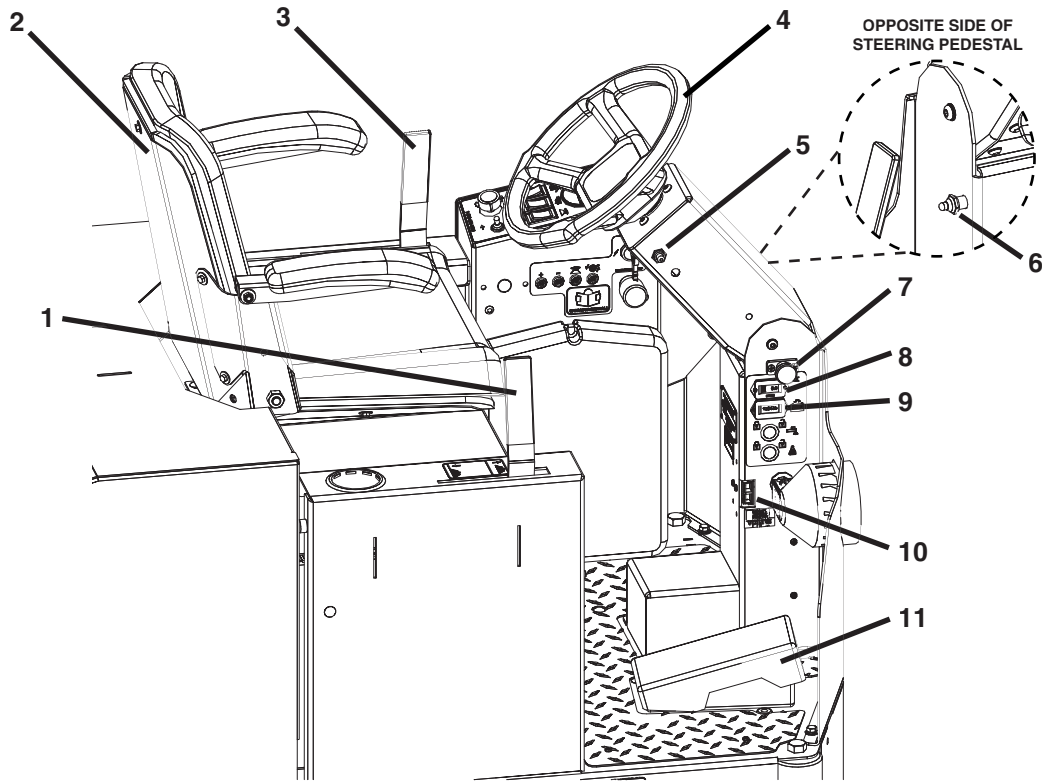

1. **SIDE BROOM LIFT LEVER:** Lifts and lowers Side Brooms that allow for debris clean up directly up to walls
2. **ADJUSTABLE SEAT WITH ARM RESTS:** The machine is equipped with an ergonomic seat with adjustable arm rests and positioning
3. **MAIN BROOM LIFT LEVER:** Lifts and lowers the Main Broom
4. **STEERING WHEEL:** Steers the main Drive Wheel
5. **HORN:** Sounds the horn for warning oncoming traffic
6. **HEADLIGHT SWITCH:** Turns power of the Headlights *ON* and *OFF*
7. **ADJUSTABLE STEERING:** Four settings for operator comfort and ease of entry
8. **HOURLY METER:** Hour meter to indicate complete time machine has been *ON*
9. **RECHARGE CYCLE METER:** Shows the amount of charges on a machine
10. **CHARGER PORT:** Grey 50 used to receive charger input for optional external charger
11. **FOOT PEDAL:** Controls the acceleration and deceleration of the machine

## MACHINE COMPONENTS

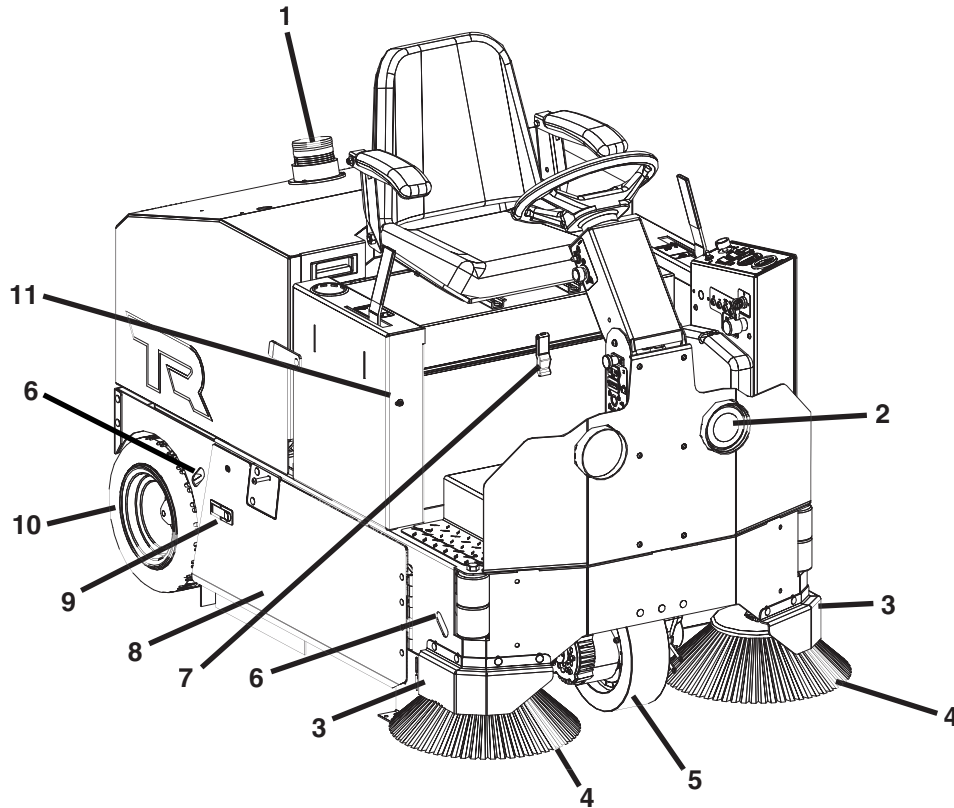

1. **STROBE LIGHT (OPTIONAL):** Optional Strobe Light silently alerts others nearby of the machines presence
2. **HEADLIGHTS:** Helps you see in low light areas and to warn oncoming traffic
3. **SIDE BROOM GUARDS (OPTIONAL):** Optional Side Broom Guards protect your Side Broom Brushes in case operator error
4. **SIDE BROOMS:** Allows for debris clean up directly up to walls
5. **FRONT DRIVE TIRE:** Drives and steers the machine
6. **TIE DOWN POINTS:** Location for tie down straps during transport
7. **FILTER ACCESS LATCH:** Latch holds the Filter Box together while also releasing and allowing access to the inside of the Filter Box
8. **SIDE ACCESS DOOR:** Protects the Main Broom and Hopper
9. **SIDE DOOR LATCH:** Opens and latches closed the Side Access Door to the Main Broom and Hopper
10. **REAR WHEELS:** Rear wheels provide three point stability for this machine
11. **SIDE BROOM ADJUSTMENT SCREW:** Turn screw counterclockwise for fine tuning of height adjustment of the Side Brooms to accommodate for brush wear

## MACHINE COMPONENTS

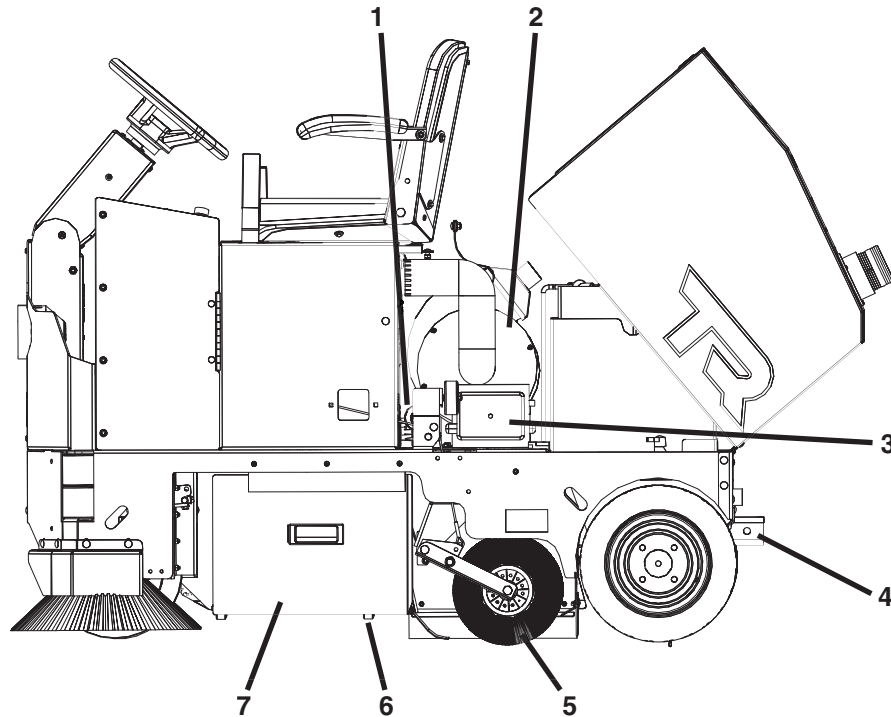

1. **FILTER MOTOR:** Powers the Beater Bar to clean out the filter
2. **MAIN BROOM MOTOR:** Powers the Main Broom and creates vacuum for the Filter Box
3. **ONBOARD CHARGER:** Easily charge your machine by conveniently pulling over and plugging in into any standard wall outlet to charge
4. **HITCH (OPTIONAL):** Used to attach rear Garbage Can Holder option
5. **MAIN BROOM:** The powerful Main Broom sweeps the floor by sweeping debris into the back of the Hopper
6. **HOPPER TRANSPORT WHEELS:** Wheels allow the Hopper to easily slide in and out from underneath the machine
7. **HOPPER:** Houses all of the dust and debris that the machine sweeps

## MACHINE SETUP

### UN-CRATING MACHINE:

Carefully check the crate for any signs of damage and that the batteries are in the unit.

To un-crate the machine, remove banding strips from around the crate. Take off the top and sides and dispose properly. Remove brackets from machine wheels. Remove bolts from pallet, then remove board. Carefully roll the machine off of the base. Notify the carrier immediately if concealed damage is discovered.

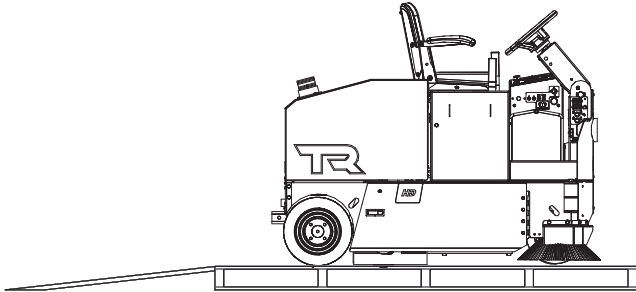

### CONNECTING BATTERIES:

Your machine is equipped with (4x) 6-Volt/ 245 AH, (4x) 6-Volt/ 325 AH, or (4x) 6-Volt/ 420 AH Wet Lead Acid, AGM, Industrial, or Deep Cycle Batteries which form a 24 Volt system.

**(SEE PICTURE BELOW OR BATTERY DISCONNECT LABEL FOR CORRECT CABLE CONNECTIONS)**

1. Turn all switches to the *OFF* position and remove Key.
2. Tip Tank back. Attach all Battery Cables to Terminals as shown below.
3. Turn *ON* main power switch and check the Battery Meter to ensure correct installation. Charge Batteries if needed **(SEE BATTERY CHARGING)**.

### NOTICE

Batteries are a possible environmental hazard. Consult your Battery supplier for safe disposal methods.

### NOTICE

Orientation of Batteries is critical for cables to reach.

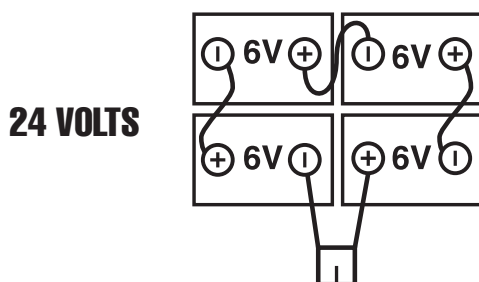

### INSTALLING MAIN BROOM:

1. Turn Key Switch to the *OFF* position and remove Key.
2. Open Side Access Door and remove bolt holding Idler Arm in place **(A) (SEE BELOW)**.

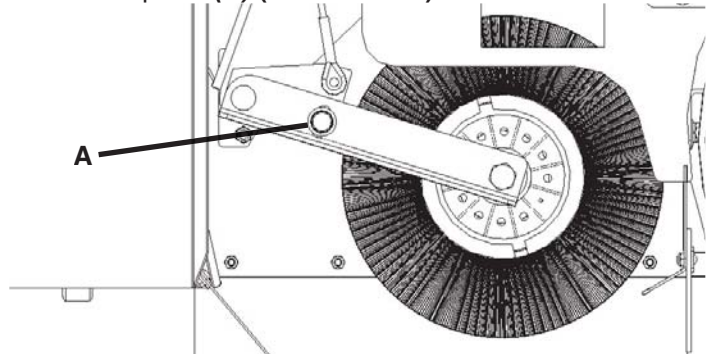

3. Remove Idler Arm and pull out old Broom **(B) (SEE BELOW)**.

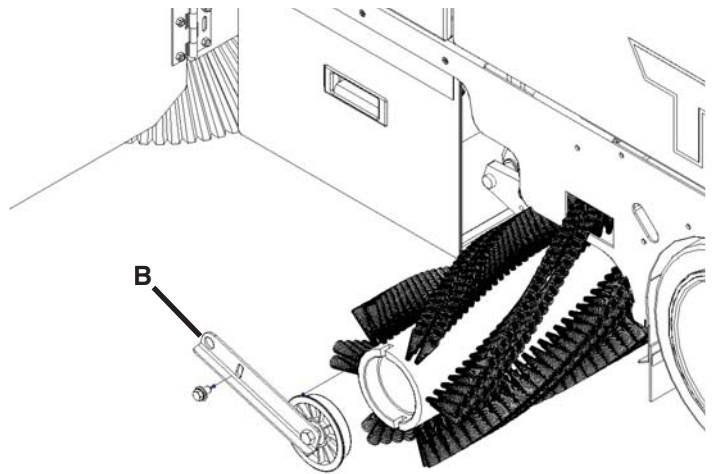

4. Slide the new Broom in. With new Broom on Driver, spin until Driver engages Broom.
5. Reinstall Idler Arm and tighten bolt **(B) (SEE ABOVE)**.
6. If Broom is not level, loosen bolt and run Main Broom motor for a couple seconds.
7. Retighten bolt and ensure Broom is level.

### NOTICE

For correct Main Broom application - Contact your Local Servicing Dealer.

#### DRIVER ALIGNED

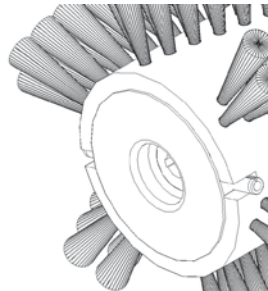

#### NOT ALIGNED

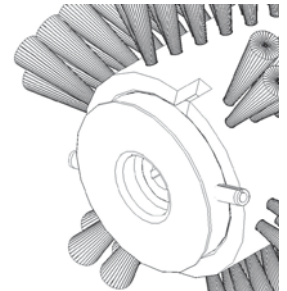

## **INSTALLING SIDE BROOMS:**

1. Lower the Side Brooms by pulling forward on the Side Broom Level and sliding to the rear.
2. Remove the Side Brooms from the box.
3. Install the Side Brooms onto the Motor Shaft. Use the bottom hole on the shaft to install the Clevis Pin and

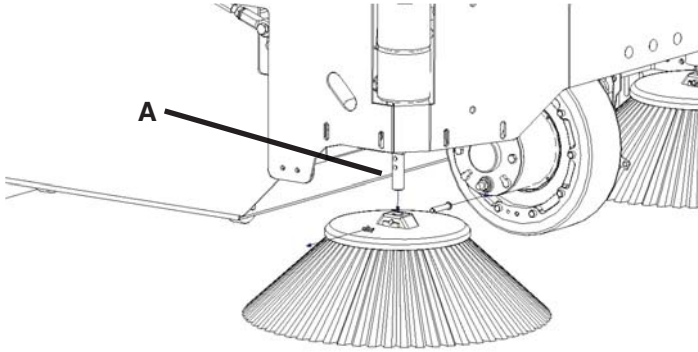

Safety Clip (A) (SEE BELOW).

4. Check Side Broom height to see if Adjustments are needed.

## **ADJUSTING SIDE BROOMS:**

1. To adjust Side Broom height, turn Adjustment Screws Clockwise to raise and Counterclockwise to lower (B) (SEE BELOW).
2. The right Side Broom bristles should contact the floor in a 10 o'clock to a 3 o'clock pattern when the Broom is in motion (C) (SEE BELOW). The left Side Broom bristles should contact the floor in a 9 o'clock to a 2 o'clock pattern when the Broom is in motion (D) (SEE BELOW).

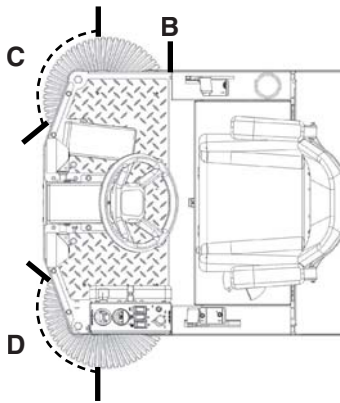

3. To raise the Side Brooms higher when in the up position, adjust the Adjustment Arm (E) (SEE BELOW).

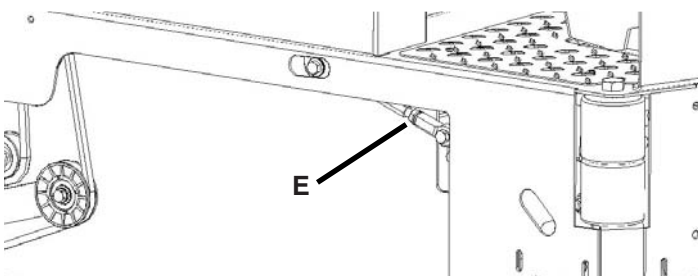

## **MACHINE SETUP**

### **PRE-CLEANING CHECKLIST:**

Read and understand the Safety Messages section on Pages 3 and 4 before operating the machine.

1. Check Battery Condition Gauge on the Control Panel. Make sure Batteries are fully charged before using.
2. Check the condition of the Brooms.
3. Check to make sure Hopper is empty.
4. Disconnect Charger and close Hood.
5. Adjust the Seat and Steering Pedestal.
6. Turn the Key Switch ON and drive to the area to be cleaned.
7. Adjust the speed of the Side Brooms to the desired speed and confirm the Side Brooms height is correct.
8. Lower the Main Broom and the Side Brooms.
9. Drive slowly.

### **OPERATING HINTS:**

1. Observe the amount of dirt/debris that the machine is sweeping up. If dirt/debris is left on ground make sure that the Wet Sweep By-Pass is not open. This feature reduces dust control and should only be used when operating on a floor with water on it.
2. Always operate at lower speeds when sweeping around walls and objects. You should reduce the speed to maintain control when turning.
3. Change or turn over Brooms when dirty.
4. Stay clear of objects protruding from the floor such as sockets, grates, etc, for they will damage the Brooms.
5. Always keep an eye on your gauges. They let you know the status of a particular system at a glance. If your battery gauge is reading low you must stop immediately and recharge. Running the Batteries dead will result in damage to the Batteries.
6. When you are ready to stop, raise the Side Brooms, raise the Main Broom, turn OFF the Side Broom Switch, turn OFF the Main Broom Switch and drive the machine back to the charging area. Be sure to clean the Hopper thoroughly before storing the machine.

### **SWEEPING:**

1. Turn on machine Key Switch **(A)**.
2. Check the Battery Gauge to ensure proper charge before starting to sweep **(B)**.
3. Lower the Main Broom to the floor by dropping the Main Broom Lift Lever forward **(C)**.
4. Lower the Side Brooms head to the floor by dropping the Side Broom Lift Lever forward **(D)**.
5. Turn on the Main Broom Motor by pressing the Main Broom Motor Switch **(E)**.
6. Turn on the Side Broom Motors by pressing the Side Broom Motors Switch **(F)**.
7. Set the speed of the Side Brooms by dialing the Side Broom Speed Control **(G)** (*Clockwise = Fastest / CounterClockwise = Slowest*).
8. Begin sweeping by depressing the Foot Pedal **(H)** slowly and then to the speed required.
9. Once the machine begins to move, check the Broom Amp Gauge **(I)**. This Gauge allows the Operator to see if there are issues in regards to the Broom type for certain applications, if something was tangled in the Broom, or other small issues that could cause the circuit to blow.
10. To operate the machine in reverse, simply switch the Reverse switch **(J)** back towards the rear of the machine. The reverse speed is set to approximately 50% of the forward speed.
11. To stop the machine, release the Foot Pedal and the machine will stop automatically **(H)**.

11. To operate the machine in reverse, simply switch the Reverse switch **(J)** back towards the rear of the machine. The reverse speed is set to approximately 50% of the forward speed.
12. To stop the machine, release the Foot Pedal and the machine will stop automatically **(H)**.

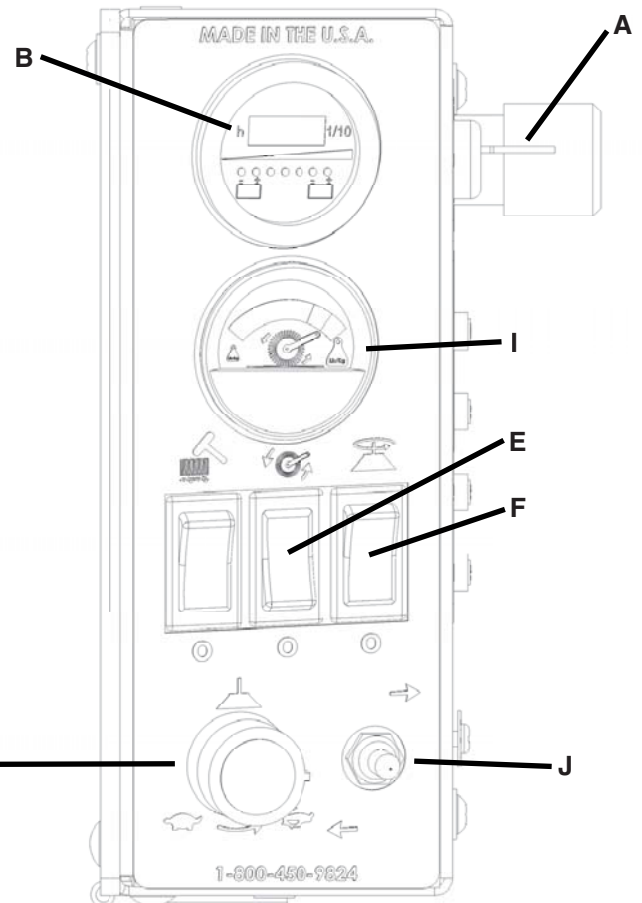
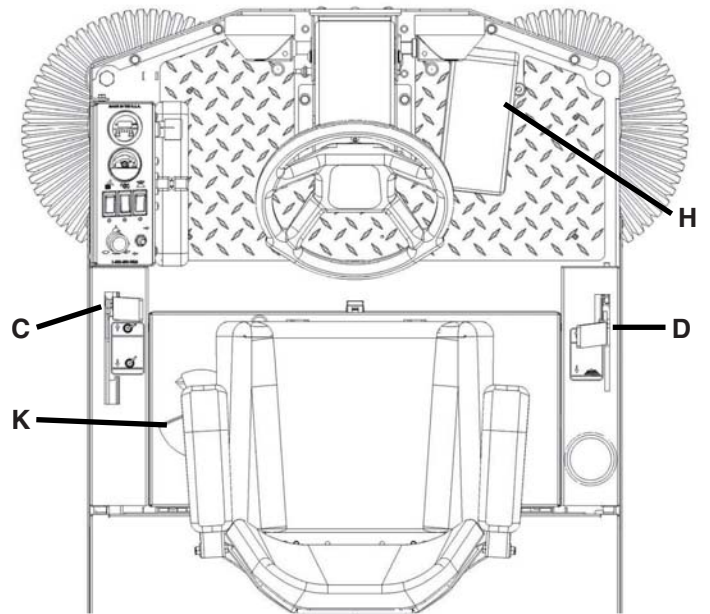

### **WET SWEEPING:**

1. Turn on machine Key Switch **(A)**.
2. Check the Battery Gauge to ensure proper charge before starting to sweep **(B)**.
3. Lower the Main Broom to the floor by dropping the Main Broom Lift Lever forward **(C)**.
4. Lower the Side Brooms head to the floor by dropping the Side Broom Lift Lever forward **(D)**.
5. Open the WET Sweep By-Pass door by rotating it clockwise **(K)**. This door being open reduces the Dust Control. Always remember to close door when sweeping again once on dry ground.
6. Turn on the Main Broom Motor by pressing the Main Broom Motor Switch **(E)**.
7. Turn on the Side Broom Motors by pressing the Side Broom Motors Switch **(F)**.
8. Set the speed of the Side Brooms by dialing the Side Broom Speed Control **(G)** (*Clockwise = Fastest / CounterClockwise = Slowest*).
9. Begin sweeping by depressing the Foot Pedal **(H)** slowly and then to the speed required.
10. Once the machine begins to move, check the Broom Amp Gauge **(I)**. This Gauge allows the Operator to see if there are issues in regards to the Broom type for certain applications, if something was tangled in the Broom, or other small issues that could cause the circuit to blow.

### **CLEANING FILTER:**

1. If dust begins to blow through the Vacuum Motor or is leaking out of the sides, then the filter needs to be cleaned.
2. Turn on machine Key Switch (A).
3. Before cleaning Filter, turn off Main Broom and Side Broom motors.
4. Clean the Filter by pressing the Shaker Switch for 20 seconds (B).

## **NOTICE**

After using the Shaker Switch let the machine sit for 30 seconds to allow the dust time to settle.

### **CHANGING FILTER:**

1. To remove Filter, open Battery Compartment Hood (C) (SEE BELOW).
2. Undo the Filter Latch and lift open the Filter Chamber Lid with the Seat on top (D).
3. Pull out old Filter and replace with new one (E).

### **EMPTY HOPPER:**

1. After machine usage, stop and shake filter.
2. Turn machine OFF and remove the key.
3. Open the Hopper Access Side Door and remove the Hopper (F).
4. Use Hopper tip lever (G) for easier dumping of contents. Clean thoroughly before placing back in machine.

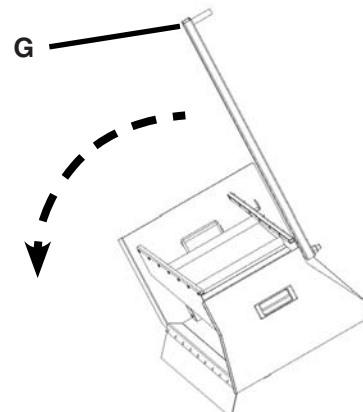
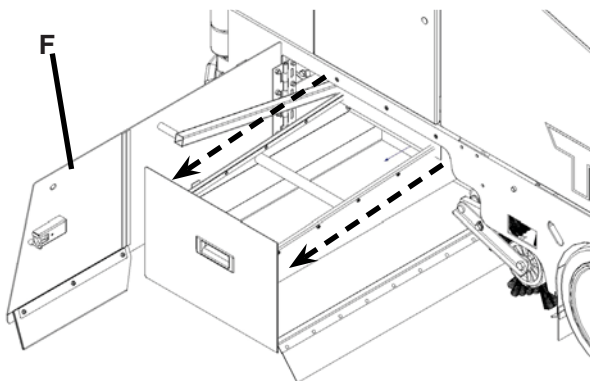
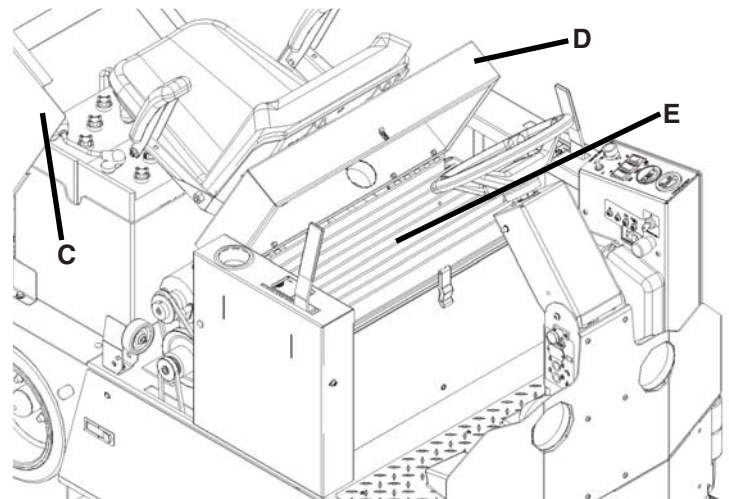
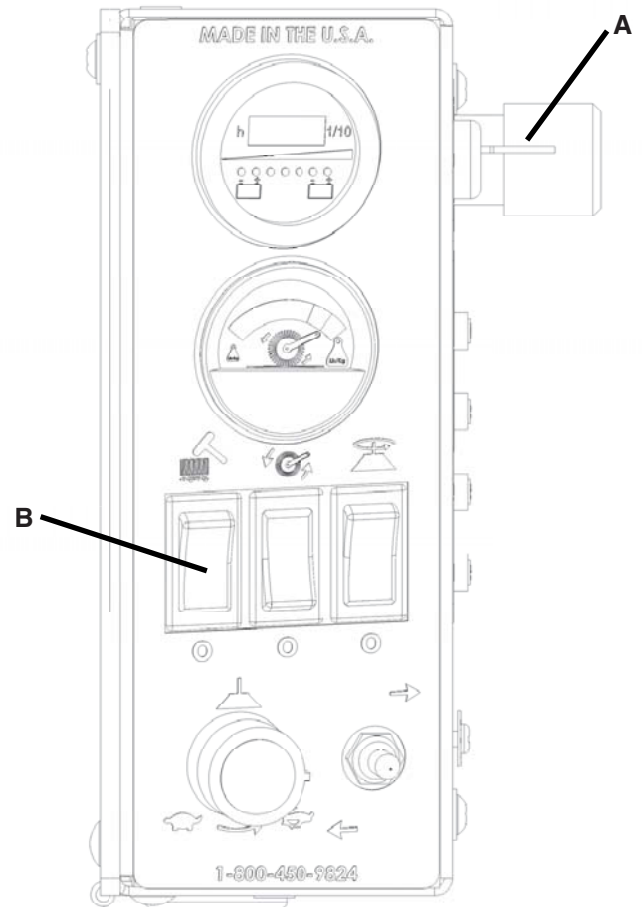

## ON-BOARD CHARGER

### Charger Specifications

- Output voltage of 24 Volts
- Output current of 40 amps max
- Input voltage of 110 Volts/ 60 Hz  
(220V/50 Hz available)
- Automatic shut off circuit
- Made for Deep Cycle Batteries

### **⚠ DANGER**

Explosive hydrogen gas forms when Batteries are charging. An open flame or spark can cause this gas to explode. Serious personal injury or property damage could occur. Only charge the Batteries in this machine in a well ventilated area.

### **⚠ WARNING**

Before you service a Battery, always wear face protection, protective gloves and protective clothing. Battery acid or battery explosion can cause serious injuries.

### **⚠ WARNING**

The Batteries in this machine contain sulfuric acid, which causes burns to skin. If battery acid contacts clothing or skin, rinse the effected area with cold water immediately. If battery acid gets on your face or in your eyes, flush the area immediately with cold water and seek medical attention.

### **⚠ CAUTION**

Always use the automatic battery charger provided by the manufacturer of this machine to charge the Batteries of this machine. It is designed to charge the Batteries at the appropriate rate. If you must use a different charger, disconnect the Batteries before charging to avoid damage to the electronic speed controller.

### **ON-BOARD BATTERY CHARGING (OPTIONAL):**

1. Transport machine to a well ventilated area for charging.
2. Turn the machine off. Open the Machine Battery Compartment.
3. Check the water in each Battery **(A)**. Do not charge the machine unless the water is slightly higher than the plates. If needed, add enough distilled water to just slightly cover the plates. Be careful not to over fill. Batteries can overflow during charging. Replace caps before charging.

4. Plug the Charger power cord **(B)** into a grounded standard wall outlet **(SEE BELOW)**.
5. The charger will automatically begin charging and automatically shut off when fully charged.
6. After the Charger has turned off, unplug the Charger from the wall outlet.
7. Recheck the cell level after charging. If needed, add distilled water up to the correct level. Be certain to replace the caps securely and to wipe off the top of the Batteries with a clean cloth.

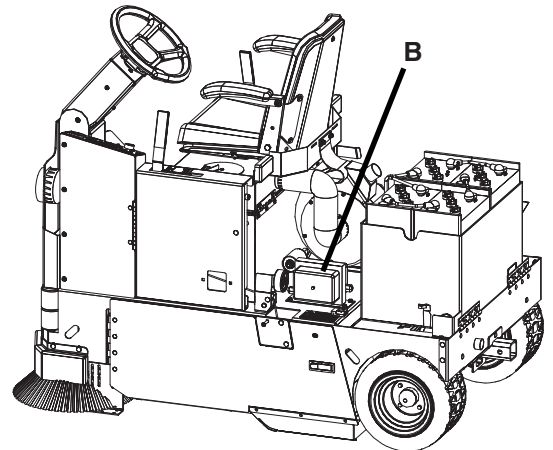
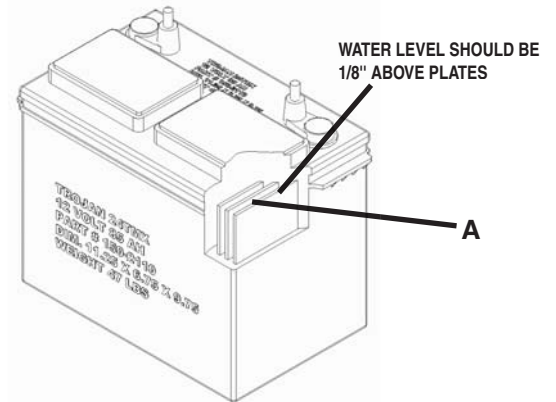

### **DESCRIPTION OF LED:**

*Red LED:* Battery level low  
*Yellow LED:* Battery at ½ charge  
*Green LED:* Battery fully charged



## BATTERY CHARGING

### Charger Specifications

- Output voltage of 24 Volts
- Output current of 40 amps max (*Optional*)
- Input voltage of 110 Volts/ 60 Hz  
(*220V/50 Hz available*)
- Automatic shut off circuit
- Made for Deep Cycle Batteries

### **⚠ DANGER**

Explosive hydrogen gas forms when Batteries are charging. An open flame or spark can cause this gas to explode. Serious personal injury or property damage could occur. Only charge the Batteries in this machine in a well ventilated area.

### **⚠ WARNING**

Before you service a Battery, always wear face protection, protective gloves and protective clothing. Battery acid or battery explosion can cause serious injuries.

### **⚠ WARNING**

The Batteries in this machine contain sulfuric acid, which causes burns to skin. If battery acid contacts clothing or skin, rinse the effected area with cold water immediately. If battery acid gets on your face or in your eyes, flush the area immediately with cold water and seek medical attention.

### **⚠ CAUTION**

Always use the automatic battery charger provided by the manufacturer of this machine to charge the Batteries of this machine. It is designed to charge the Batteries at the appropriate rate. If you must use a different charger, disconnect the Batteries before charging to avoid damage to the electronic speed controller.

### EXTERNAL BATTERY CHARGING:

1. Transport machine to a well ventilated area for charging.
2. Turn the machine off. Open the Machine Battery Compartment.
3. Check the water in each Battery (**A**). Do not charge the machine unless the water is slightly higher than the plates. If needed, add enough distilled water to just slightly cover the plates. Be careful not to over fill. Batteries can overflow during charging. Replace caps before charging.
4. First, disconnect the batteries by unplugging the red

50 Charger plug. Connect the red 50 Charger plug to the machine's Charger (**B**). While the Charger plug is connected, plug the charger power cord into a grounded 110 Volt standard wall outlet (**C**).

5. The Charger will automatically begin charging and automatically shut off when fully charged (*check Battery gauge*).
6. After the Charger has turned off - First, unplug the Charger from the wall outlet. Second, unplug the red 50 Charger plug from the Batteries and reconnect the Batteries.
7. Recheck the cell level after charging. If needed, add distilled water up to the correct level. Be certain to replace the caps securely and to wipe off the top of the Batteries with a clean cloth.

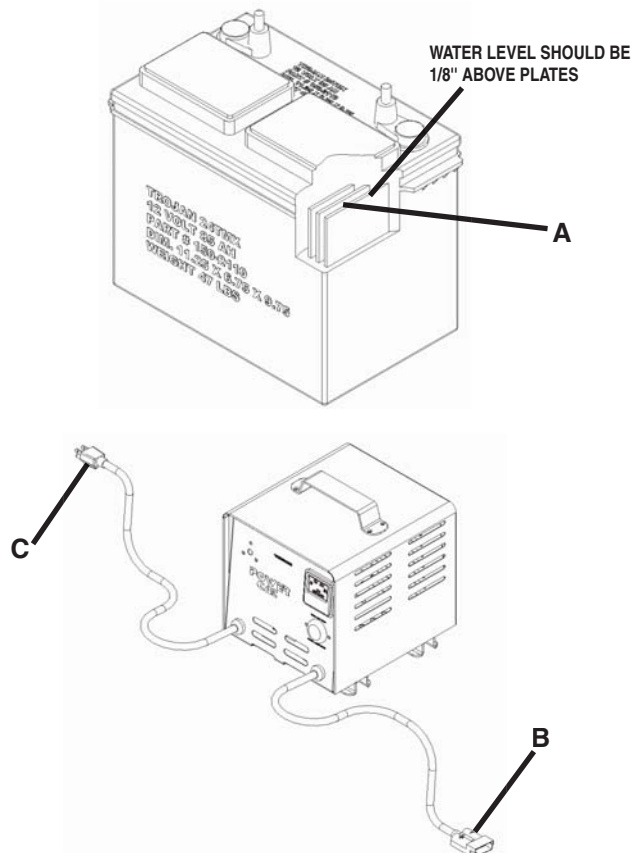

## BATTERY MAINTENANCE GUIDE

### SAFETY:

#### **⚠ DANGER**

Explosive hydrogen gas forms when Batteries are charging. An open flame or spark can cause this gas to explode. Serious personal injury or property damage could occur. Only charge the Batteries in this machine in a well ventilated area.

#### **⚠ WARNING**

Before you service a Battery, always wear face protection, protective gloves and protective clothing. Battery acid or battery explosion can cause serious injuries.

#### **⚠ WARNING**

The Batteries in this machine produce hazardous voltage which can cause electrical shock, burns and/or electrocution. Always disconnect Batteries before servicing this machine.

#### **⚠ WARNING**

The Batteries in this machine contain sulfuric acid, which causes burns to skin. If battery acid contacts clothing or skin, rinse the effected area with cold water immediately. If battery acid gets on your face or in your eyes, flush the area immediately with cold water and seek medical attention.

#### **⚠ WARNING**

Dress safely. Do not wear rings or metal wrist watches when servicing this machine, as they can cause an electrical short circuit which can cause serious burns.

### INSPECTION AND CLEANING:

- Keep Batteries clean and dry from residue
- Check that all vent caps are tight
- Use a solution of baking soda and water to clean if acid residue on Batteries or corrosion on the terminals
- Protective spray of petroleum jelly should be applied to terminals to reduce corrosion

### STORAGE:

- Batteries should be fully charged prior to and during storage
- Never store discharged Batteries
- Store Batteries in a cool, dry place but never below freezing - Recharge in storage a minimum of every 30 days
- Recharge Batteries before putting them back into service

### WATERING:

- Add water, NEVER ACID, to cells (*distilled water recommended*).
- Do not over water
- Before charging the Batteries, only add water if the plates are exposed. Add just enough water to cover the plates, then charge the batteries. Once fully charged, add water to the proper level as indicated below.
- For full charge plus series Batteries add water to the maximum water level indicator (**A**).
- After watering, secure vent caps back on Batteries.

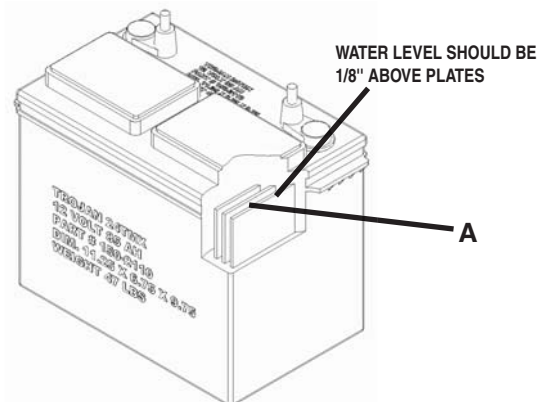

## MAINTENANCE

### DAILY MAINTENANCE:

1. Remove the clean Brushes. Never use soiled Brushes when cleaning. Replace Brushes when they become worn.
2. Press Filter Shaker Switch for 20 seconds to clean out Filter. Inspect filter.
3. Pull out Hopper to empty and clean before machine storage.
4. Wipe down machine if needed. Use a non-abrasive, non-solvent cleaner or a clean damp cloth.
5. Recharge the Batteries if needed.

### WEEKLY MAINTENANCE:

1. Check Battery water level in each cell of the Batteries and fill as needed. Always use distilled water to refill Batteries. Batteries should be filled approximately  $\frac{3}{4}$ " to 1" above the plates. Overfilling will cause the Batteries to leak during charging. The charging process creates gas bubbles inside the Battery, which effectively increases the volume of the electrolyte.
2. Clean Battery tops to prevent corrosion.
3. Flip Brushes.
4. Pull out Hopper to empty and clean before machine storage.

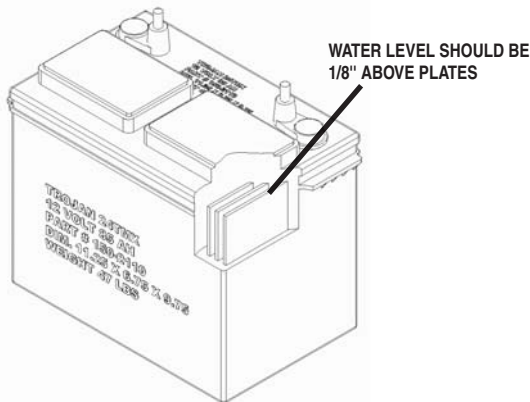

### MONTHLY MAINTENANCE:

1. Check Main Broom Jackshaft Belt for wear and tension.
2. Check machine for Vacuum Leaks.
3. Inspect the Dust Curtains and replace if torn or worn.
4. Check to see if Battery cables are tightened. Tighten, if needed, 8-10 ft/lb MAX.
5. Insept all Cables and Springs,.
6. Insept all Nuts, Bolts, and Fasteners.

### YEARLY MAINTENANCE:

Call your local dealer for yearly maintenance.

### STORING MACHINE:

1. Be sure to clean the Hopper out completely.

### CHECKING BATTERY SPECIFIC GRAVITY:

Use a hydrometer to check the Battery specific gravity.

Checking Gravity:

- Hydrometer
- Battery

### NOTICE

Do not take readings immediately after adding distilled water. If water and acid are not thoroughly mixed, the reading may not be accurate.

Check the hydrometer against this chart

SPECIFIC GRAVITY @ 80°F (27°C)	BATTERY CONDITION
1.265	100% Charged
1.225	75% Charged
1.190	50% Charged
1.155	25% Charged
1.120	Discharged

### NOTICE

If the readings are taken when the battery electrolyte is any temperature other than 80°F(27°C), the reading must be temperature corrected. To find the corrected specific gravity reading when the temperature of the battery electrolyte is other than 80°F(27°C): add (+) to the specific gravity reading 0.004 (4 points), for each 10°F(6°C) above 80°F(27°C). Subtract (-) from the specific reading 0.004 (4 points), for each 10°F(6°C) below 80°F(27°C).

## PM RECORDS

### CUSTOMER INFORMATION

CUSTOMER		EMAIL	
ADDRESS			PHONE
CITY	STATE	ZIP	CONTACT

### MACHINE INFORMATION

MODEL #:	SERIAL #:
WORK ORDER#:	HOUR METER (Key):
CHASSIS HOUR METER:	HOUR METER (Traction):
RECHARGE NUMBER:	HOUR METER (Scrub):
ISOLATOR HOUR METER:	RE-CHARGE COUNTER:

**NOTE:** Isolators need to be replaced on Scrubber Machines at 250 Hours or Annually

BATTERY CONDITION	CELL 1	CELL 2	CELL 3	CELL 4	CELL 5	CELL 6
BATTERY 1 HYDROMETER						
BATTERY 1 WATER CONDITION						
BATTERY 2 HYDROMETER						
BATTERY 2 WATER CONDITION						
BATTERY 3 HYDROMETER						
BATTERY 3 WATER CONDITION						
BATTERY 4 HYDROMETER						
BATTERY 4 WATER CONDITION						

CLEAN BATTERY TOPS. CHECK BATTERY CABLE AND TERMINAL CONDITION.

NOTES:

### PAD/BRUSH CONDITION

MAIN BROOM FIBER LENGTH	ROTATED BRUSHES		
BROOM DRIVER	GOOD	WORN	NEEDS REPLACEMENT
BROOM DRIVER & IDLER HUBS	GOOD	WORN	NEEDS REPLACEMENT
SIDE BROOM CONDITION	GOOD	WORN	NEEDS REPLACEMENT ROTATED SIDE TO SIDE

CHECK OPERATION AND CONDITION OF:	IN SPEC	REPAIR	PROBLEM
MAIN POWER SWITCH OR KEY SWITCH			
STEERING WHEEL TILT MECHANISM			
HORN			
HEAD LIGHTS			
BATTERY / HOUR METER GAUGE			
BROOM AMP GAUGE			
MAIN BROOM SWITCH			
SIDE BROOM SWITCH			
FILTER SHAKER SWITCH			
FORWARD / REVERSE SWITCH			
FOOT PEDAL			
BACK UP ALARM			
SIDE BROOM SPEED CONTROL RHEOSTAT			
MAIN BROOM BELTS			

MAIN BROOM LIFT CABLE			
SIDE BROOM LIFT MECHANISM			
MAIN BROOM MOTOR			
SIDE BROOM OPERATION			
STROBE LIGHT			
BATTERY CHARGER CONNECTORS			
BATTERY CHARGER			

CLEAN AND / OR LUBRICATE	IN SPEC	REPAIR	PROBLEM
FILTER (20 SEC W/ SHAKER SWITCH)			
HOPPER			
SIDE BROOM LINKAGE			
REMOVE BROOM & CHECK DRIVERS FOR DEBRIS			
STEERING CHAIN			

VISUALLY INSPECT	IN SPEC	REPAIR	PROBLEM
SEAL UNDER FILTER			
HOPPER CURTAIN			
HOPPER SIDE CURTAIN			
MAIN BROOM CURTAIN (REAR)			
SIDE DOOR CURTAIN			
INNER SIDE CURTAIN			
VACUUM HOSE			
DRIVE WHEEL CONDITION			
REAR WHEELS CONDITION			

COMMENTS

SERVICING DISTRIBUTOR \_\_\_\_\_

TECHNICIAN'S NAME \_\_\_\_\_ DATE \_\_\_\_\_ SIGNATURE \_\_\_\_\_

CUSTOMER'S NAME \_\_\_\_\_ DATE \_\_\_\_\_ SIGNATURE \_\_\_\_\_

## TROUBLE-SHOOTING

PROBLEM	CAUSE	SOLUTION
No power - Nothing operates	Faulty Key Switch Batteries need charging Faulty Batteries Loose Battery Cable	Contact Local Servicing Dealer See <b>CHARGING BATTERIES</b> Replace Battery Tighten loose cable
Main Broom does not sweep	Main Broom is not down Foot Pedal is not depressed Main Broom Circuit Breaker tripped Carbon Brushes worn Fault Motor or Wires	Slide Main Broom Lever to the down position Engage Foot Pedal Reset 40 Amp Breaker Contact Local Servicing Dealer Contact Local Servicing Dealer
Drive Motor does not operate	Recharge Switch misadjusted Faulty Speed Controller or Wires Faulty Drive Motor Faulty Wiring Carbon Brushes worn	Contact Local Servicing Dealer Contact Local Servicing Dealer Contact Local Servicing Dealer Contact Local Servicing Dealer Contact Local Servicing Dealer
Drive Motor runs incorrectly	Faulty Speed Controller or Wires Faulty Potentiometer Loose Wires	Contact Local Servicing Dealer Contact Local Servicing Dealer Contact Local Servicing Dealer
Poor Dust Control	Filter clogged Hopper Gasket faulty Hopper full Faulty Vacuum fan Battery Charge is low Wet Sweep By-pass Door is open	Press Filter Shaker Switch for 20 seconds Replace Gasket Empty Hopper Contact Local Servicing Dealer Fully charge batteries Close By-pass Door

## MACHINE SPECS

### **BODY CONSTRUCTION/DIMENSIONS**

Frame Construction:	TR 3/16" Steel (.47625 cm)
Front Drive Wheel:	10" x 3" [25 x 8 cm]
Rear Wheels:	(2x) 14" x 5" [(2x) 36 x 13 cm]
Size (L x W x H):	64" x 37" x 50" (163 x 94 x 140 cm)
Weight (without Batteries):	850 lb
Weight (with standard Batteries):	1140 lb

### **SWEEPING SYSTEM**

Sweeping Method:	Direct Throw
Broom (length x dia):	32" x 10" (81 x 25 cm)
Broom Power/Speed:	1.0 hp / 435 rpm
Side Broom Size:	(2x) 17"
Side Broom Power:	(2x) 0.3 hp
Side Broom Speed:	100 rpm
Hopper Capacity	4.2 cubic ft

### **FILTERING SYSTEM**

Filtering Material:	Polymer Felt
Filter Rating:	1 Micron
Size:	5,182 sq. inches
Vacuum Rating:	280 cfm

### **BATTERY SYSTEM**

System Voltage:	24 Volts
Standard Battery Ah Rating:	(4x) 245 Ah
Optional Battery Ah Rating:	Up to (4x) 420 Ah
Battery Run Time (Standard):	Up to 7 Hrs
Charger (Automatic):	25 Amp

### **DRIVE SYSTEM**

Drive Power:	2.0 hp (1491 watts)
Speed Control:	0-4 mph

### **PRODUCTIVITY**

Cleaning Width:	46"
Cleaning Rate:	60,568 sq.ft/hr

### **GENERAL**

Sound Level:	71 dBA
Standard Equipment:	Low Battery Indicator
Optional Equipment:	Non-Marking Tires, Artificial Turf Package, Strobe Light

## COMMON WEAR PARTS

### CYLINDRICAL BROOMS:

BROOM TYPE	PART #S
Poly	4-401
Nylon	4-401N
Carpet Broom	4-401NN
Poly & Steel	4-401S
Union	4-401U
Union & Steel	4-401US

### SIDE BROOMS:

SIDE BROOM TYPE	PART#S
Poly	4-402
Poly & Steel	4-402S

### FILTER KITS:

FILTER TYPE	PART#S
<b>Standard Filter Assembly</b> <small>(Includes Tape Seal Kit, Grill, and Filter)</small>	4-500
<b>Standard Filter Kit</b> <small>(Includes Tape Seal Kit and Filter)</small>	4-502D
<b>1 Micron Filter</b>	4-502
<b>0.2 Micron Filter</b>	4-502F
<b>Nomex Filter</b>	4-502N
<b>Filter Tape Seal Kit</b>	4-502K



## STANDARD WARRANTY POLICY

RPS Corporation warrants its machines, parts and accessories to be free of manufacturer's defects for the periods specified below. Warranty will be granted at the sole discretion of RPS Corporation and is subject to final claim and parts review by R.P.S. Corporation and its vendors. This policy is effective January 1, 2013 and is subject to change on production units at a future date.

### COVERAGE, EXCLUSIONS AND LIMITATIONS:

**Coverage:** All Models sold (Except Floor Machines: 1 Year Parts / 6 Months Labor / No Travel)

**Parts:** 36 months / 1,500 hours on "Power On" hour meter

**Labor:** 12 months

**Travel:** 3 months (150 mile maximum)

**Poly Tanks:** 7 Years (Water must not exceed 135°F/57°C) / 3,000 Hours

**OEM Parts:** 90 Day New Part Warranty

**Validity:** Fully completed Machine Delivery Form (online or fax) is on record at RPS and machine is serviced by Factory Authorized Personnel.

**Limitation:** Warranty will begin on date of machine installation to end-user or 6 months after shipment from RPS Corp. to the distributor if unsold at that time.

This warranty includes all parts on the machine except normal wear parts. Some of these exceptions are:

- EDGE / ORBITZ isolators (250 hours on average)
- Squeegee Blades, Wiper Blades, Skirts and Curtains.
- Caster Wheels, Squeegee Wheels and Bumpers.
- Lights (Strobe, Headlights, or Bulbs).
- Chains and Belts.
- Filters, Screens, and Vacuum Bags.
- Motor Brushes and commutator wear.
- Brooms, Brushes, Pads and Pad Retainers.
- Hoses and Tubing.
- Drive Tires, Pneumatic Wheels and Tubes.
- Rubber Floor Seals and Gaskets.
- Vacuum motors with evidence of moisture or debris intrusion or > 400 hours.
- The Batteries (see below).
- **NOT COVERED:** Routine maintenance, adjustments or parts damaged from abuse, neglect, improper use of the machine, or lack of scheduled "daily, weekly, monthly" maintenance in accordance with our published PM Sheets.

**POLY TANKS:** 7 Years Coverage against leakage due to manufacturer's defect in materials or workmanship. Tank warranty void if water used exceeds 135°F/57°C

**NOTE:** Freight coverage for 3 Years under the parts section of warranty.

**BATTERIES:** Warranted through battery manufacturer for **One (1) Year** (pro-rated) from the date of delivery. The battery manufacturer approves or denies the warranty coverage after analysis. We rely on solely on their review.

**NOTE NOT COVERED:** Damage from lack of water, failure to use OEM charger, or non-distilled water. Battery terminals – Battery terminals and cable connections are covered for 30 days from the shipment of the machine. (Battery terminals tightness should be inspected every 30 days.)

## MACHINE INSTALL / WARRANTY REGISTRATION

**Installing Dealer:** \_\_\_\_\_ **Installed By:** \_\_\_\_\_

**Location: (City, State):** \_\_\_\_\_ **Install Date:** \_\_\_\_\_

**End-User Company Name:** \_\_\_\_\_ **End-User Contact:** \_\_\_\_\_

**Address:** \_\_\_\_\_ **City/State:** \_\_\_\_\_ **Zip:** \_\_\_\_\_

**Phone:** \_\_\_\_\_ **Fax:** \_\_\_\_\_ **Email:** \_\_\_\_\_

**Model:** \_\_\_\_\_ **Serial #:** \_\_\_\_\_ **Hour Meter:** \_\_\_\_\_

**BUYER'S REPRESENTATIVE HAS RECEIVED INSTRUCTION IN PROPER OPERATION OF THE FOLLOWING CONTROLS AND FEATURES:**

### SCRUBBERS:

- Filling solution tank, Solution tank sight tube, Solution drain hose or valve for flushing and freezing conditions
- Adjusting controls & operation, Double scrubbing, Squeegee lift delay, High Recovery RED Light, vacuum switch (horn honking) and vacuum timer
- Recovery tank draining & cleaning, Common Squeegee hose clog points, vacuum screen removal and cleaning, drain saver basket emptied.
- Shroud and pad/brush removal and installation
- Side Wiper and Curtain adjustment and maintenance for water control
- Solution valve and filter operation (removal and cleaning)
- LCD display operation, 4 hour meters (key switch, brush, traction drive, vacuum)
- Tank tilt back feature, only when both tanks are fully drained
- Squeegee hose removal and checking for clogs

### BURNISHERS

- Train and have customer demonstrate proper removal and replacement of burnishing pad
- Pad pressure gauge and proper operating range to avoid tripping the circuit breaker

### SWEEPERS

- Demonstrate proper removal and replacement of main broom and side brooms
- Method for cleaning the dust filter, emptying out the debris hopper and correct installation
- Correct operation of the main broom and side broom levers, and understands to park with brushes in UP position
- Trained on the "Wet-Sweep" bypass door and not to operate through standing water

### EDGE MACHINES

- EDGE scrubbers must have their isolators & deck hour meter replaced every 250 hours of use.
- Customer understands the Grip Face is not warranted against damage from improper use or direct contact with the floor.

### ALL MACHINES

- Checking for proper battery electrolyte level, electrolyte condition monthly, and check that battery terminals are properly torqued to 10ft/lbs.
- Parking brake override
- Charging operation and customer understands batteries have limited "cycles" and recharging = 1 cycle
- Seat and steering wheel adjustment
- Customer has read and understands the list of WARNINGS/CAUTIONS in the Operator manual
- Battery and Machine Maintenance Guide posters hung up and reviewed
- Manufacturer's website is a good source of information (Videos, PM Sheets) and sign up for quarterly newsletters
- Operators and Parts manuals were delivered, reviewed, understood, and confirmation preventive maintenance is done every 100 hours of use and recorded on PM Sheets provided online or in manuals.

**Installed By (print)** \_\_\_\_\_ **Signature** \_\_\_\_\_

**Buyers Representative (print)** \_\_\_\_\_ **Signature** \_\_\_\_\_

**Buyer agrees to pay for any repairs, adjustments, or secondary training that manufacturer determines is excluded from the warranty.**

**Complete and Fax form to 1-866-632-6961 or Online at [www.rpsccorporation.com](http://www.rpsccorporation.com)**





1711 South Street  
Racine, WI 53404  
[www.rpscorporation.com](http://www.rpscorporation.com)  
[www.factorycat.com](http://www.factorycat.com)  
[www.tomcatequip.com](http://www.tomcatequip.com)  
Tel. US: 800-634-4060  
Tel. Int: (011) 262-681-3583  
Fax: 866-901-3335